



RIGOL

# DG5000 Pro Series

Function/Arbitrary Waveform Generator

Performance Verification

Jun. 2025

## **Guaranty and Declaration**

### **Copyright**

© 2025 RIGOL TECHNOLOGIES CO., LTD. All Rights Reserved.

### **Trademark Information**

RIGOL® is the trademark of RIGOL TECHNOLOGIES CO., LTD.

### **Notices**

- RIGOL products are covered by P.R.C. and foreign patents, issued and pending.
- RIGOL reserves the right to modify or change parts of or all the specifications and pricing policies at the company's sole decision.
- Information in this publication replaces all previously released materials.
- Information in this publication is subject to change without notice.
- RIGOL shall not be liable for either incidental or consequential losses in connection with the furnishing, use, or performance of this manual, as well as any information contained.
- Any part of this document is forbidden to be copied, photocopied, or rearranged without prior written approval of RIGOL.

### **Product Certification**

RIGOL guarantees that this product conforms to the national and industrial standards in China as well as the ISO9001:2015 standard and the ISO14001:2015 standard. Other international standard conformance certifications are in progress.

### **Contact Us**

If you have any problem or requirement when using our products or this manual, please contact RIGOL.

E-mail: [service@rigol.com](mailto:service@rigol.com)

Website: <http://www.rigol.com>

Section	Description	Page
1	Safety Requirement .....	1
1.1	General Safety Summary .....	1
1.2	Safety Notices and Symbols .....	3
2	Document Overview .....	4
3	Overview .....	6
3.1	Test Preparations .....	6
3.2	Recommended Test Equipment .....	6
3.3	Test Considerations .....	7
3.4	Test Result Record .....	7
3.5	Specifications .....	7
4	Performance Verification Test .....	8
4.1	Frequency Accuracy Test .....	8
4.1.1	Specification .....	8
4.1.2	Test Procedures .....	8
4.1.3	Test Record Form .....	9
4.2	AC Amplitude Accuracy Test .....	11
4.2.1	Specification .....	11
4.2.2	Test Procedures .....	12
4.2.3	Test Record Form .....	13
4.3	DC Offset Accuracy Test .....	17
4.3.1	Specification .....	17
4.3.2	Test Procedures .....	17
4.3.3	Test Record Form .....	18
4.4	AC Flatness Test .....	21
4.4.1	Specification .....	21
4.4.2	Test Procedures .....	22
4.4.3	Test Record Form .....	24
4.5	Harmonic Distortion Test .....	28
4.5.1	Specification .....	28
4.5.2	Test Procedures .....	28
4.5.3	Test Record Form .....	30
4.6	Spurious Signal Test .....	36
4.6.1	Specification .....	36

---

4.6.2 Test Procedures .....	37
4.6.3 Test Record Form .....	38
4.7 Overshoot Test .....	41
4.7.1 Specification .....	41
4.7.2 Test Procedures .....	41
4.7.3 Test Record Form .....	42
5 Appendix: Test Record Form .....	44

# 1 Safety Requirement

---

## 1.1 General Safety Summary

---

Please review the following safety precautions carefully before putting the instrument into operation so as to avoid any personal injury or damage to the instrument and any product connected to it. To prevent potential hazards, please follow the instructions specified in this manual to use the instrument properly.

- **Use the BNC Output Connectors Properly.**

The front-panel BNC output connectors only allow signal output but do not support signal input.

- **Use Proper Power Cord.**

Only the exclusive power cord designed for the instrument and authorized for use within the local country could be used.

- **Ground the Instrument.**

The instrument is grounded through the Protective Earth lead of the power cord. To avoid electric shock, it is essential to connect the earth terminal of the power cord to the Protective Earth terminal before connecting any inputs or outputs.

- **Observe All Terminal Ratings.**

To avoid fire or shock hazard, observe all ratings and markers on the instrument and check your manual for more information about ratings before connecting the instrument.

- **Use Proper Overvoltage Protection.**

Ensure that no overvoltage (such as that caused by a bolt of lightning) can reach the product. Otherwise, the operator might be exposed to the danger of an electric shock.

- **Do Not Operate Without Covers.**

Do not operate the instrument with covers or panels removed.

- **Do Not Insert Objects Into the Air Outlet.**

Do not insert anything into the holes of the fan to avoid damaging the instrument.

- **Use Proper Fuse.**

Please use the specified fuses.

- **Avoid Circuit or Wire Exposure.**

Do not touch exposed junctions and components when the unit is powered on.

- **Do Not Operate With Suspected Failures.**

If you suspect damage occurs to the instrument, have it inspected by RIGOL authorized personnel before further operations. Any maintenance, adjustment or replacement especially to circuits or accessories must be performed by RIGOL authorized personnel.
- **Provide Adequate Ventilation.**

Inadequate ventilation may cause an increase of temperature in the instrument, which would cause damage to the instrument. So please keep the instrument well ventilated and inspect the air outlet and the fan regularly.
- **Do Not Operate in Wet Conditions.**

To avoid short circuit inside the instrument or electric shock, never operate the instrument in a humid environment.
- **Do Not Operate in an Explosive Atmosphere.**

To avoid personal injuries or damage to the instrument, never operate the instrument in an explosive atmosphere.
- **Keep Instrument Surfaces Clean and Dry.**

To avoid dust or moisture from affecting the performance of the instrument, keep the surfaces of the instrument clean and dry.
- **Prevent Electrostatic Impact.**

Operate the instrument in an electrostatic discharge protective environment to avoid damage induced by static discharges. Always ground both the internal and external conductors of cables to release static before making connections.
- **Use the Battery Properly.**

Do not expose the battery (if available) to high temperature or fire. Keep it out of the reach of children. Improper change of a battery (lithium battery) may cause an explosion. Use the RIGOL specified battery only.
- **Handle with Caution.**

Please handle with care during transportation to avoid damage to keys, knobs, interfaces, and other parts on the panels.

**WARNING**

**Equipment meeting Class A requirements may not offer adequate protection to broadcast services within residential environment.**

## 1.2 Safety Notices and Symbols

### Safety Notices in this Manual:



#### **WARNING**

Indicates a potentially hazardous situation or practice which, if not avoided, will result in serious injury or death.



#### **CAUTION**

Indicates a potentially hazardous situation or practice which, if not avoided, could result in damage to the product or loss of important data.

### Safety Notices on the Product:

- **DANGER**

It calls attention to an operation, if not correctly performed, could result in injury or hazard immediately.

- **WARNING**

It calls attention to an operation, if not correctly performed, could result in potential injury or hazard.

- **CAUTION**

It calls attention to an operation, if not correctly performed, could result in damage to the product or other devices connected to the product.

### Safety Symbols on the Product:



**Hazardous Voltage**



**Safety Warning**



**Protective Earth Terminal**

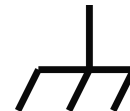

**Chassis Ground**



**Test Ground**

## 2 Document Overview

This manual is designed to guide you to properly test the performance specifications of RIGOL DG5000 Pro Series Function/Arbitrary Waveform Generator. For the operation methods mentioned in the test procedures, refer to User Guide of this product.

### Publication Number

PVB18101-1110

### Format Conventions in this Manual

#### 1. Key

The front panel key is denoted by the menu key icon. For example,  indicates the "Default" key.

#### 2. Menu

The menu item is denoted by the format of "Menu Name (Bold) + Character Shading" in the manual. For example, **Setup**.

#### 3. Operation Procedures

The next step of the operation is denoted by ">" in the manual. For example, .

> **Utility** indicates first clicking or tapping  and then clicking or tapping **Utility**.

### Content Conventions in this Manual

DG5000 Pro Series Function/Arbitrary Waveform Generator includes the following models. Unless otherwise specified, this manual takes DG5508 Pro as an example to illustrate the performance verification methods of DG5000 Pro series.

Model	No. of Channels	Sample Rate	Max. Output Frequency
DG5252 Pro	2	2.5 GSa/s	250 MHz
DG5254 Pro	4	2.5 GSa/s	250 MHz
DG5258 Pro	8	2.5 GSa/s	250 MHz
DG5352 Pro	2	2.5 GSa/s	350 MHz
DG5354 Pro	4	2.5 GSa/s	350 MHz
DG5358 Pro	8	2.5 GSa/s	350 MHz
DG5502 Pro	2	2.5 GSa/s	500 MHz

---

Model	No. of Channels	Sample Rate	Max. Output Frequency
DG5504 Pro	4	2.5 GSa/s	500 MHz
DG5508 Pro	8	2.5 GSa/s	500 MHz

## 3 Overview

### 3.1 Test Preparations

Before the test, please make sure that the instrument is within the calibration period (1 year recommended) and has been operating for at least 30 minutes at a specified operating temperature ( $23^{\circ}\text{C}\pm 5^{\circ}\text{C}$ ).

### 3.2 Recommended Test Equipment

Use the test equipment listed in the following table to verify the performance of DG5000 Pro. If the exact instrument model is not available, it is recommended to select the substitute equipment that can meet the following "Specification".

**Table 3.1 Recommended Test Equipment**

Equipment	Specification	Recommended Model
Frequency Counter	>10 MHz Accuracy: 0.1 ppm	Agilent 53131A
Digital Multimeter	6½ digits	RIGOL DM3068
Power Meter	-30 dBm to +20 dBm Accuracy: $\pm 0.02$ dB Resolution: 0.01 dB	Agilent E4416A
Spectrum Analyzer	Min. resolution bandwidth: $\leq 10$ Hz	RIGOL RSA5032
Oscilloscope	Bandwidth: $\geq 2$ GHz Rise/Fall time measurement function Overshoot measurement function	RIGOL DS70000
Cable	BNC (m)-BNC (m)	-
Cable	BNC (m)-Dual Banana Plug (m)	-
50 $\Omega$ Load	50 $\Omega$ /1 W	-
Power Sensor	-35 dBm to +20 dBm	Agilent N8482A

Equipment	Specification	Recommended Model
Power Sensor Cable	Used to connect the power meter and power sensor	-
Adaptor	N (f)-BNC (m)	-
Adaptor	BNC (f)-N (m)	-

### 3.3 Test Considerations

For better performance, all procedures should comply with the following recommendations:

1. Before making the performance verification test, please make sure that the instrument has been operating for at least 30 minutes at a specified operating temperature ( $23^{\circ}\text{C}\pm 5^{\circ}\text{C}$ ).
2. Each test should be performed at the specified operating temperature ( $23^{\circ}\text{C}\pm 5^{\circ}\text{C}$ ).
3. Please reset the instrument to the factory setting before or after executing any of the tests.

### 3.4 Test Result Record

Record and keep the test result of each test. In the final chapter of this manual, a test result record form is provided. The form lists all the test items and their corresponding performance limits as well as spaces for users to record the test results.

#### TIP

It is recommended that users photocopy the test record form before each test and record the test results in the copy so that the form can be used repeatedly.

### 3.5 Specifications

The specification of each test item is provided in this manual. For other technical parameters, refer to DG5000 Data Sheet (download it from RIGOL website: [www.rigol.com](http://www.rigol.com)).

#### TIP

All the specifications are valid only when the instrument has been operating for more than 30 minutes within the specified operating temperature range ( $23^{\circ}\text{C}\pm 5^{\circ}\text{C}$ ).

## 4 Performance Verification Test

This chapter takes the CH1 of DG5508 Pro as an example to illustrate the performance verification test methods of the DG5000 Pro series. The testing methods are also applicable to other channels.

### 4.1 Frequency Accuracy Test

#### 4.1.1 Specification

Frequency Accuracy	
Specification	$\pm 10^{-6}$ of the setting value (except Arb), 0°C to 50°C $\pm 10^{-6}$ of the setting value $\pm 1$ $\mu$ Hz (Arb), 0°C to 50°C

#### 4.1.2 Test Procedures

- As shown in the figure below, use the dual BNC cable to connect the output terminal of DG5000 Pro to the signal input terminal of the frequency counter. This case takes CH1 as an example. The test method also applies to other channels.

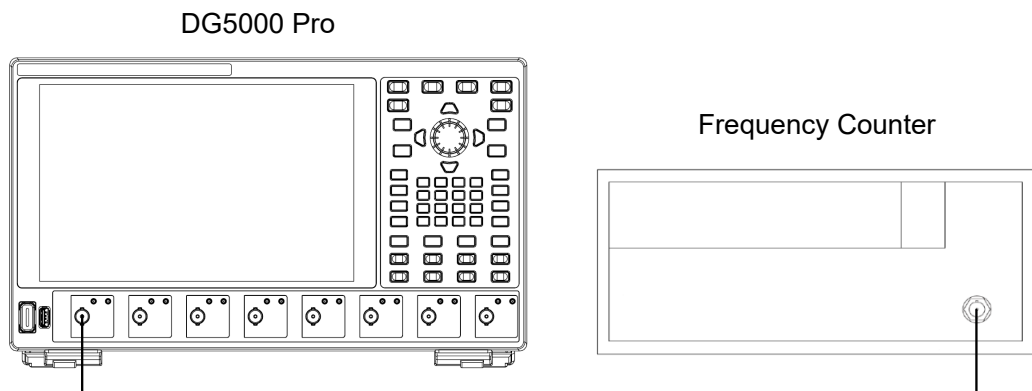

- Set the input impedance of the frequency counter to 1 M $\Omega$ .
- Press the front-panel **Default** key of DG5000 Pro and a prompt message is displayed. Click or tap **OK** to restore the instrument to its factory default settings.
- Configure DG5000 Pro:
  - Set CH1 to output a Sine wave with 1 MHz frequency and 1 V<sub>pp</sub> amplitude.
  - Press the front-panel CH1 key to enable the output of CH1. You can also click or tap the channel identifier of the Channel Setup Interface to enable the output.

5. Record the current reading on the frequency counter and verify that the reading is between 0.999999 MHz and 1.000001 MHz.
6. Set DG5000 Pro to output Square, Ramp, Pulse, and Harmonics respectively (1 MHz frequency, 1 Vpp amplitude). Record the reading on the counter respectively and verify that the reading is within 0.999999 MHz and 1.000001 MHz.
7. Repeat the steps above to test the frequency accuracy for other channels and record the test results.

### 4.1.3 Test Record Form

#### Channel: CH1

Waveform	Setting	Measured Value	Limit <sup>[1]</sup>	Pass/Fail
Sine	Frequency: 1 MHz Amplitude: 1 Vpp		0.999999 MHz to 1.000001 MHz	
Square			0.999999 MHz to 1.000001 MHz	
Ramp			0.999999 MHz to 1.000001 MHz	
Pulse			0.999999 MHz to 1.000001 MHz	
Harmonic			0.999999 MHz to 1.000001 MHz	

#### Channel: CH2

Waveform	Setting	Measured Value	Limit <sup>[1]</sup>	Pass/Fail
Sine	Frequency: 1 MHz Amplitude: 1 Vpp		0.999999 MHz to 1.000001 MHz	
Square			0.999999 MHz to 1.000001 MHz	
Ramp			0.999999 MHz to 1.000001 MHz	
Pulse			0.999999 MHz to 1.000001 MHz	
Harmonic			0.999999 MHz to 1.000001 MHz	

#### Channel: CH3

Waveform	Setting	Measured Value	Limit <sup>[1]</sup>	Pass/Fail
Sine	Frequency: 1 MHz		0.999999 MHz to 1.000001 MHz	
Square	Amplitude: 1 Vpp		0.999999 MHz to 1.000001 MHz	

Waveform	Setting	Measured Value	Limit <sup>[1]</sup>	Pass/Fail
Ramp			0.999999 MHz to 1.000001 MHz	
Pulse			0.999999 MHz to 1.000001 MHz	
Harmonic			0.999999 MHz to 1.000001 MHz	

**Channel: CH4**

Waveform	Setting	Measured Value	Limit <sup>[1]</sup>	Pass/Fail
Sine	Frequency: 1 MHz Amplitude: 1 Vpp		0.999999 MHz to 1.000001 MHz	
Square			0.999999 MHz to 1.000001 MHz	
Ramp			0.999999 MHz to 1.000001 MHz	
Pulse			0.999999 MHz to 1.000001 MHz	
Harmonic			0.999999 MHz to 1.000001 MHz	

**Channel: CH5**

Waveform	Setting	Measured Value	Limit <sup>[1]</sup>	Pass/Fail
Sine	Frequency: 1 MHz Amplitude: 1 Vpp		0.999999 MHz to 1.000001 MHz	
Square			0.999999 MHz to 1.000001 MHz	
Ramp			0.999999 MHz to 1.000001 MHz	
Pulse			0.999999 MHz to 1.000001 MHz	
Harmonic			0.999999 MHz to 1.000001 MHz	

**Channel: CH6**

Waveform	Setting	Measured Value	Limit <sup>[1]</sup>	Pass/Fail
Sine	Frequency: 1 MHz Amplitude: 1 Vpp		0.999999 MHz to 1.000001 MHz	
Square			0.999999 MHz to 1.000001 MHz	
Ramp			0.999999 MHz to 1.000001 MHz	
Pulse			0.999999 MHz to 1.000001 MHz	

Waveform	Setting	Measured Value	Limit <sup>[1]</sup>	Pass/Fail
Harmonic			0.999999 MHz to 1.000001 MHz	

**Channel: CH7**

Waveform	Setting	Measured Value	Limit <sup>[1]</sup>	Pass/Fail
Sine	Frequency: 1 MHz Amplitude : 1 Vpp		0.999999 MHz to 1.000001 MHz	
Square			0.999999 MHz to 1.000001 MHz	
Ramp			0.999999 MHz to 1.000001 MHz	
Pulse			0.999999 MHz to 1.000001 MHz	
Harmonic			0.999999 MHz to 1.000001 MHz	

**Channel: CH8**

Waveform	Setting	Measured Value	Limit <sup>[1]</sup>	Pass/Fail
Sine	Frequency: 1 MHz Amplitude: 1 Vpp		0.999999 MHz to 1.000001 MHz	
Square			0.999999 MHz to 1.000001 MHz	
Ramp			0.999999 MHz to 1.000001 MHz	
Pulse			0.999999 MHz to 1.000001 MHz	
Harmonic			0.999999 MHz to 1.000001 MHz	

Note<sup>[1]</sup>: The limit is calculated from the frequency setting value (1 MHz)  $\pm$  permissible error. The permissible error is the setting value of  $\pm 10^{-6}$  (except Arb), 0°C to 50°C.

## 4.2 AC Amplitude Accuracy Test

### 4.2.1 Specification

AC Amplitude Accuracy <sup>[1]</sup>	
Specification	$\pm(1\% \text{ of the setting value} + +1 \text{ mVpp})(\text{into } 50 \Omega)$

Note<sup>[1]</sup>: 1 kHz Sine, amplitude > 1 mVpp, 0 V offset, unit: Vpp.

## 4.2.2 Test Procedures

1. Connect the 50  $\Omega$  load to the output terminal of DG5000 Pro, as shown in the figure below. This case takes CH1 as example. The test method also applies to other channels. Then use the BNC-dual banana plug cable to connect the 50  $\Omega$  load and the voltage input terminal of the digital multimeter.

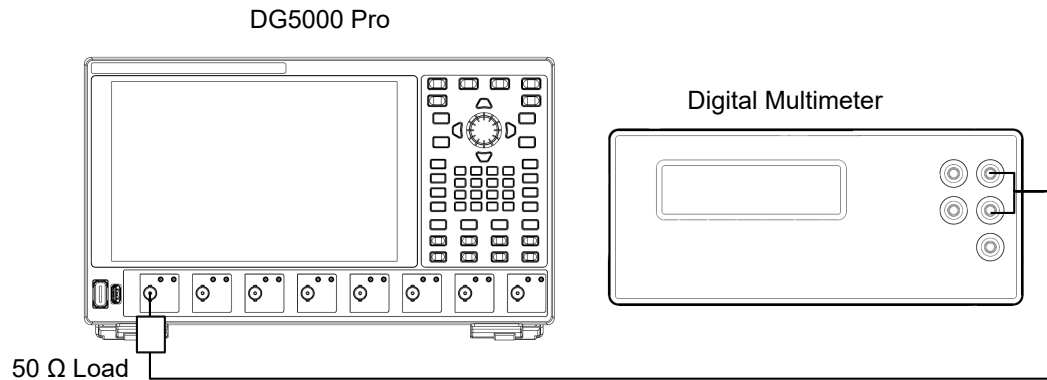

2. Select the AC voltage (ACV) measurement function for the multimeter and set the range to "2 V".
3. Press the front-panel **Default** key of DG5000 Pro and a prompt message is displayed. Click or tap **OK** to restore the instrument to its factory default settings.
4. Configure DG5000 Pro:
  - a. Set the output impedance of CH1 to 50  $\Omega$  (in CH1 setup interface, click or tap the **Channel** tab and select "Load" in the drop-down menu of **Imped**).
  - b. Set CH1 to output a Sine wave with 1 kHz frequency, 0 Vdc offset, and 20 mVpp amplitude.
  - c. Press the front-panel CH1 key to enable the output of CH1. You can also click or tap the channel identifier of the Channel Setup Interface to enable the output.
5. Record the reading on the multimeter and verify that the reading is within the range specified in the "Limits of Amplitude Output Value (Vrms)".
6. Keep other settings unchanged for DG5000 Pro and adjust the output waveform amplitude of CH1 to 100 mVpp, 500 mVpp, 1 Vpp, 5 Vpp, and 10 Vpp respectively. When the amplitude of the output waveform is set to 100 mVpp or 500 mVpp, keep the 2 V range for the multimeter; when the amplitude of the output waveform is set to 1 Vpp, 5 Vpp, or 10 Vpp, set the range to 20 V. Record the reading on the multimeter and verify that the reading is within the range specified in the "Limits of Amplitude Output Value (Vrms)".

Amplitude Setting (Vpp)	Permissible Error <sup>[1]</sup> (Vpp)	Limits of Amplitude Output Value (Vpp)	Limits of Amplitude Output Value (Vrms) <sup>[2]</sup>
20 mVpp	±1.2 mV	18.8 mVpp to 21.2 mVpp	6.6 mVrms to 7.5 mVrms
100 mVpp	±2 mV	98 mVpp to 102 mVpp	34.6 mVrms to 36.1 mVrms
500 mVpp	±6 mV	494 mVpp to 506 mVpp	174.7 mVrms to 178.9 mVrms
1 Vpp	±11 mV	0.989 Vpp to 1.011 Vpp	349.7 mVrms to 357.4 mVrms
5 Vpp	±51 mV	4.949 Vpp to 5.051 Vpp	1.7497Vrms to 1.7857 Vrms
10 Vpp	±101 mV	9.899 Vpp to 10.101 Vpp	3.4998 Vrms to 3.5712 Vrms

Note<sup>[1]</sup>: "Permissible Error" is calculated from the specification " $\pm(1\%$  of the setting value + 1 mVpp)".

Note<sup>[2]</sup>: "Limits of Amplitude Output Value (Vrms)" is calculated from "Limits of Amplitude Output Value (Vpp)". The conversion relationship between Vrms and Vpp:  $V_{pp} = 2\sqrt{2} V_{rms}$ .

- Repeat the steps above to test the AC amplitude accuracy for other channels and record the test results.

### 4.2.3 Test Record Form

Channel: CH1

Amplitude Setting	Setting	Measured Value	Limit <sup>[1]</sup>	Pass/Fail
20 mVpp	Frequency: 1 kHz Offset: 0 Vdc Impedance: 50 $\Omega$		6.6 mVrms to 7.5 mVrms	
100 mVpp			34.6 mVrms to 36.1 mVrms	
500 mVpp			174.7 mVrms to 178.9 mVrms	
1 Vpp			349.7 mVrms to 357.4 mVrms	
5 Vpp			1.7497Vrms to 1.7857 Vrms	

Amplitude Setting	Setting	Measured Value	Limit <sup>[1]</sup>	Pass/Fail
10 Vpp			3.4998 mVrms to 3.5712 mVrms	

**Channel: CH2**

Amplitude Setting	Setting	Measured Value	Limit <sup>[1]</sup>	Pass/Fail
20 mVpp	Frequency: 1 kHz Offset: 0 Vdc Impedance: 50 Ω		6.6 mVrms to 7.5 mVrms	
100 mVpp			34.6 mVrms to 36.1 mVrms	
500 mVpp			174.7 mVrms to 178.9 mVrms	
1 Vpp			349.7 mVrms to 357.4 mVrms	
5 Vpp			1.7497Vrms to 1.7857 Vrms	
10 Vpp			3.4998 mVrms to 3.5712 mVrms	

**Channel: CH3**

Amplitude Setting	Setting	Measured Value	Limit <sup>[1]</sup>	Pass/Fail
20 mVpp	Frequency: 1 kHz Offset: 0 Vdc Impedance: 50 Ω		6.6 mVrms to 7.5 mVrms	
100 mVpp			34.6 mVrms to 36.1 mVrms	
500 mVpp			174.7 mVrms to 178.9 mVrms	
1 Vpp			349.7 mVrms to 357.4 mVrms	
5 Vpp			1.7497Vrms to 1.7857 Vrms	
10 Vpp			3.4998 mVrms to 3.5712 mVrms	

**Channel: CH4**

Amplitude Setting	Setting	Measured Value	Limit <sup>[1]</sup>	Pass/Fail
20 mVpp	Frequency: 1 kHz		6.6 mVrms to 7.5 mVrms	

Amplitude Setting	Setting	Measured Value	Limit <sup>[1]</sup>	Pass/Fail
100 mVpp	Offset: 0 Vdc Impedance: 50 Ω		34.6 mVrms to 36.1 mVrms	
500 mVpp			174.7 mVrms to 178.9 mVrms	
1 Vpp			349.7 mVrms to 357.4 mVrms	
5 Vpp			1.7497Vrms to 1.7857 Vrms	
10 Vpp			3.4998 mVrms to 3.5712 mVrms	

**Channel: CH5**

Amplitude Setting	Setting	Measured Value	Limit <sup>[1]</sup>	Pass/Fail
20 mVpp	Frequency: 1 kHz Offset: 0 Vdc Impedance: 50 Ω		6.6 mVrms to 7.5 mVrms	
100 mVpp			34.6 mVrms to 36.1 mVrms	
500 mVpp			174.7 mVrms to 178.9 mVrms	
1 Vpp			349.7 mVrms to 357.4 mVrms	
5 Vpp			1.7497Vrms to 1.7857 Vrms	
10 Vpp			3.4998 mVrms to 3.5712 mVrms	

**Channel: CH6**

Amplitude Setting	Setting	Measured Value	Limit <sup>[1]</sup>	Pass/Fail
20 mVpp	Frequency: 1 kHz Offset: 0 Vdc Impedance: 50 Ω		6.6 mVrms to 7.5 mVrms	
100 mVpp			34.6 mVrms to 36.1 mVrms	
500 mVpp			174.7 mVrms to 178.9 mVrms	
1 Vpp			349.7 mVrms to 357.4 mVrms	

Amplitude Setting	Setting	Measured Value	Limit <sup>[1]</sup>	Pass/Fail
5 Vpp			1.7497Vrms to 1.7857 Vrms	
10 Vpp			3.4998 mVrms to 3.5712 mVrms	

**Channel: CH7**

Amplitude Setting	Setting	Measured Value	Limit <sup>[1]</sup>	Pass/Fail
20 mVpp			6.6 mVrms to 7.5 mVrms	
100 mVpp			34.6 mVrms to 36.1 mVrms	
500 mVpp	Frequency: 1 kHz Offset: 0 Vdc		174.7 mVrms to 178.9 mVrms	
1 Vpp	Impedance: 50 Ω		349.7 mVrms to 357.4 mVrms	
5 Vpp			1.7497Vrms to 1.7857 Vrms	
10 Vpp			3.4998 mVrms to 3.5712 mVrms	

**Channel: CH8**

Amplitude Setting	Setting	Measured Value	Limit <sup>[1]</sup>	Pass/Fail
20 mVpp			6.6 mVrms to 7.5 mVrms	
100 mVpp			34.6 mVrms to 36.1 mVrms	
500 mVpp	Frequency: 1 kHz Offset: 0 Vdc		174.7 mVrms to 178.9 mVrms	
1 Vpp	Impedance: 50 Ω		349.7 mVrms to 357.4 mVrms	
5 Vpp			1.7497Vrms to 1.7857 Vrms	
10 Vpp			3.4998 mVrms to 3.5712 mVrms	

Note<sup>[1]</sup>: 1 kHz Sine, amplitude > 1 mVpp, 0 V offset, unit: Vpp. ±(1% of the setting value + 1 mVpp).

## 4.3 DC Offset Accuracy Test

### 4.3.1 Specification

DC Offset Accuracy	
Specification	$\pm(1\% \text{ of }  \text{setting value}  + 1 \text{ mV} + 0.5\% \text{ of amplitude (Vpp)})(\text{into } 50 \Omega)$

### 4.3.2 Test Procedures

1. Connect the 50  $\Omega$  load to the output terminal of DG5000 Pro, as shown in the figure below. This case takes CH1 as example. The test method also applies to other channels. Then use the BNC-dual banana plug cable to connect the 50  $\Omega$  load and the voltage input terminal of the digital multimeter.

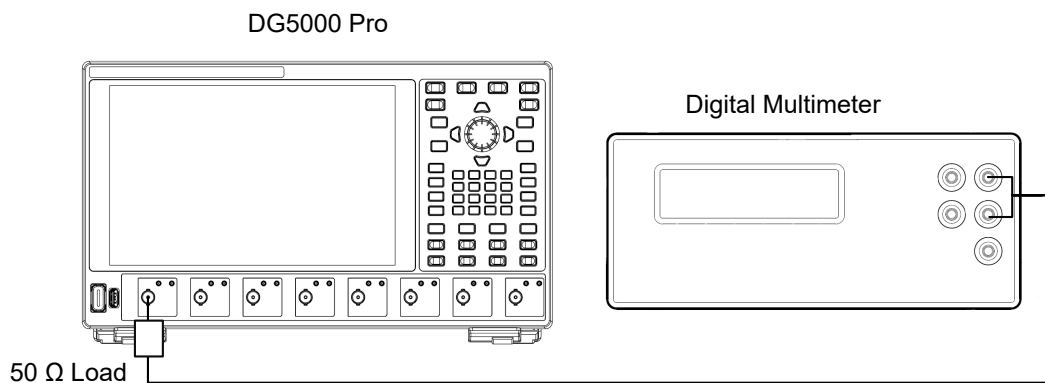

2. Select the DC voltage (DCV) measurement function for the multimeter and set the range to 20 V.
3. Press the front-panel **Default** key of DG5000 Pro and a prompt message is displayed. Click or tap **OK** to restore the instrument to its factory default settings.
4. Configure DG5000 Pro:
  - a. Set the output impedance of CH1 to 50  $\Omega$  (in CH1 setup interface, click or tap the **Channel** tab and select "Load" in the drop-down menu of **Imped**).
  - b. Set CH1 to output a Sine wave with 1 kHz frequency, 5 Vpp amplitude, and 0 Vdc offset.
  - c. Press the front-panel CH1 key to enable the output of CH1. You can also click or tap the channel identifier of the Channel Setup Interface to enable the output.
5. Record the reading on the multimeter and verify that the reading is within the range specified in the "Offset Limit" of the table below.

6. Keep the other settings unchanged and adjust the output waveform offset of CH1 to -2.5 Vdc, -1 Vdc, -500 mVdc, 500 mVdc, 1 Vdc, and 2.5 Vdc respectively. Record the reading on the multimeter and verify that the reading is within the "Offset Limit" specified in the table below.

Offset Setting	Amplitude Setting	Permissible Error <sup>[1]</sup>	Offset Limit
-2.5 Vdc	5 Vpp	±0.051 Vdc	-2.551 Vdc to -2.449 Vdc
-1 Vdc		±0.036 Vdc	-1.036 Vdc to -0.964 Vdc
-500 mVdc		±0.031 Vdc	-0.531 Vdc to -0.469 Vdc
0 Vdc		±0.026 Vdc	-0.026 Vdc to +0.026 Vdc
+500 mVdc		±0.031 Vdc	0.469 Vdc to 0.531 Vdc
+1 Vdc		±0.036 Vdc	0.964 Vdc to 1.036 Vdc
+2.5 Vdc		±0.051 Vdc	2.449 Vdc to 2.551 Vdc

Note<sup>[1]</sup>: "Permissible Error" is calculated from the specification " $\pm(1\% \text{ of } |\text{the setting value}| + 1 \text{ mV} + 0.5\% \text{ of the amplitude (Vpp)})$ ".

7. Repeat the steps above to verify the DC offset accuracy for other channels and record the test result.

### 4.3.3 Test Record Form

Channel: CH1

Offset Setting	Setting	Measured Value	Limit <sup>[1]</sup>	Pass/Fail
-2.5 Vdc	Frequency: 1 kHz Amplitude: 5 Vpp Impedance: 50 Ω		-2.551 Vdc to -2.449 Vdc	
-1 Vdc			-1.036 Vdc to -0.964 Vdc	
-500 mVdc			-0.531 Vdc to -0.469 Vdc	
0 Vdc			-0.026 Vdc to +0.026 Vdc	
500 mVdc			0.469 Vdc to 0.531 Vdc	
1 Vdc			0.964 Vdc to 1.036 Vdc	
2.5 Vdc			2.449 Vdc to 2.551 Vdc	

**Channel: CH2**

Offset Setting	Setting	Measured Value	Limit <sup>[1]</sup>	Pass/Fail
-2.5 Vdc	Frequency: 1 kHz Amplitude: 5 Vpp Impedance: 50 Ω		-2.551 Vdc to -2.449 Vdc	
-1 Vdc			-1.036 Vdc to -0.964 Vdc	
-500 mVdc			-0.531 Vdc to -0.469 Vdc	
0 Vdc			-0.026 Vdc to +0.026 Vdc	
500 mVdc			0.469 Vdc to 0.531 Vdc	
1 Vdc			0.964 Vdc to 1.036 Vdc	
2.5 Vdc			2.449 Vdc to 2.551 Vdc	

**Channel: CH3**

Offset Setting	Setting	Measured Value	Limit <sup>[1]</sup>	Pass/Fail
-2.5 Vdc	Frequency: 1 kHz Amplitude: 5 Vpp Impedance: 50 Ω		-2.551 Vdc to -2.449 Vdc	
-1 Vdc			-1.036 Vdc to -0.964 Vdc	
-500 mVdc			-0.531 Vdc to -0.469 Vdc	
0 Vdc			-0.026 Vdc to +0.026 Vdc	
500 mVdc			0.469 Vdc to 0.531 Vdc	
1 Vdc			0.964 Vdc to 1.036 Vdc	
2.5 Vdc			2.449 Vdc to 2.551 Vdc	

**Channel: CH4**

Offset Setting	Setting	Measured Value	Limit <sup>[1]</sup>	Pass/Fail
-2.5 Vdc	Frequency: 1 kHz Amplitude: 5 Vpp Impedance: 50 Ω		-2.551 Vdc to -2.449 Vdc	
-1 Vdc			-1.036 Vdc to -0.964 Vdc	
-500 mVdc			-0.531 Vdc to -0.469 Vdc	
0 Vdc			-0.026 Vdc to +0.026 Vdc	
500 mVdc			0.469 Vdc to 0.531 Vdc	

Offset Setting	Setting	Measured Value	Limit <sup>[1]</sup>	Pass/Fail
1 Vdc			0.964 Vdc to 1.036 Vdc	
2.5 Vdc			2.449 Vdc to 2.551 Vdc	

**Channel: CH5**

Offset Setting	Setting	Measured Value	Limit <sup>[1]</sup>	Pass/Fail
-2.5 Vdc	Frequency: 1 kHz Amplitude: 5 Vpp Impedance: 50 Ω		-2.551 Vdc to -2.449 Vdc	
-1 Vdc			-1.036 Vdc to -0.964 Vdc	
-500 mVdc			-0.531 Vdc to -0.469 Vdc	
0 Vdc			-0.026 Vdc to +0.026 Vdc	
500 mVdc			0.469 Vdc to 0.531 Vdc	
1 Vdc			0.964 Vdc to 1.036 Vdc	
2.5 Vdc			2.449 Vdc to 2.551 Vdc	

**Channel: CH6**

Offset Setting	Setting	Measured Value	Limit <sup>[1]</sup>	Pass/Fail
-2.5 Vdc	Frequency: 1 kHz Amplitude: 5 Vpp Impedance: 50 Ω		-2.551 Vdc to -2.449 Vdc	
-1 Vdc			-1.036 Vdc to -0.964 Vdc	
-500 mVdc			-0.531 Vdc to -0.469 Vdc	
0 Vdc			-0.026 Vdc to +0.026 Vdc	
500 mVdc			0.469 Vdc to 0.531 Vdc	
1 Vdc			0.964 Vdc to 1.036 Vdc	
2.5 Vdc			2.449 Vdc to 2.551 Vdc	

**Channel: CH7**

Offset Setting	Setting	Measured Value	Limit <sup>[1]</sup>	Pass/Fail
-2.5 Vdc	Frequency: 1 kHz		-2.551 Vdc to -2.449 Vdc	

Offset Setting	Setting	Measured Value	Limit <sup>[1]</sup>	Pass/Fail
-1 Vdc	Amplitude: 5 Vpp Impedance: 50 Ω		-1.036 Vdc to -0.964 Vdc	
-500 mVdc			-0.531 Vdc to -0.469 Vdc	
0 Vdc			-0.026 Vdc to +0.026 Vdc	
500 mVdc			0.469 Vdc to 0.531 Vdc	
1 Vdc			0.964 Vdc to 1.036 Vdc	
2.5 Vdc			2.449 Vdc to 2.551 Vdc	

**Channel: CH8**

Offset Setting	Setting	Measured Value	Limit <sup>[1]</sup>	Pass/Fail
-2.5 Vdc	Frequency: 1 kHz Amplitude: 5 Vpp Impedance: 50 Ω		-2.551 Vdc to -2.449 Vdc	
-1 Vdc			-1.036 Vdc to -0.964 Vdc	
-500 mVdc			-0.531 Vdc to -0.469 Vdc	
0 Vdc			-0.026 Vdc to +0.026 Vdc	
500 mVdc			0.469 Vdc to 0.531 Vdc	
1 Vdc			0.964 Vdc to 1.036 Vdc	
2.5 Vdc			2.449 Vdc to 2.551 Vdc	

Note<sup>[1]</sup>: The offset limit value is calculated from the offset setting value  $\pm$  permissible error. The permissible error is calculated from the specification " $\pm(1\%$  of |the setting value| + 1 mV + 0.5% of the amplitude (Vpp))".

## 4.4 AC Flatness Test

### 4.4.1 Specification

AC Flatness	
Flatness	Typical <sup>[1]</sup> <5 MHz: $\pm 0.1$ dB $\geq 5$ MHz to <50 MHz: $\pm 0.2$ dB

**AC Flatness**

$\geq 50$ MHz to $< 100$ MHz: $\pm 0.5$ dB
$\geq 100$ MHz to $< 200$ MHz: $\pm 1.0$ dB
$\geq 200$ MHz: $\pm 2.0$ dB

[1]: 1  $\mu$ Hz to 200 kHz relative to 1 kHz Sine,  $> 200$  kHz relative to 1 MHz Sine; 0 dBm amplitude.

## 4.4.2 Test Procedures

### Test Procedures

AC flatness testing is divided into low-frequency band testing ( $\leq 200$  kHz) and high-frequency band testing ( $> 200$  kHz). Use a digital multimeter for low-frequency testing and a power meter for high-frequency testing.

1. Connect the 50  $\Omega$  load to the output terminal of DG5000 Pro, as shown in the figure below. This case takes CH1 as example. The test method also applies to other channels. Then use the BNC-dual banana plug cable to connect the 50  $\Omega$  load and the voltage input terminal of the digital multimeter.

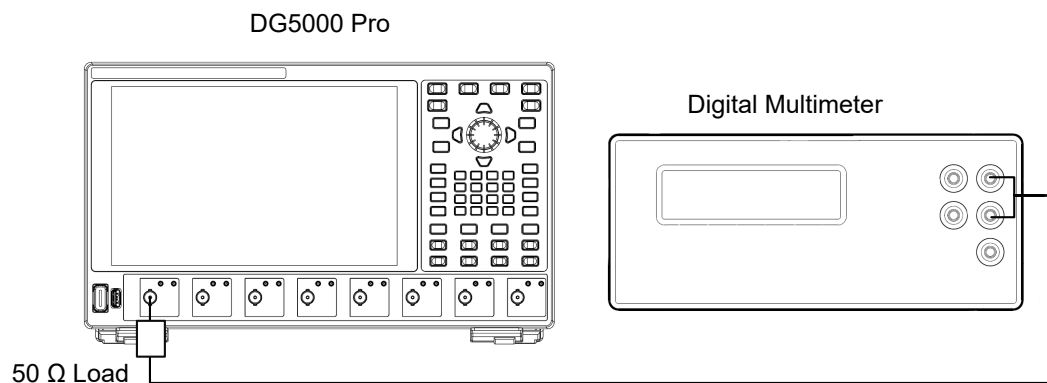



2. Press the front-panel **Default** key of DG5000 Pro and a prompt message is displayed. Click or tap **OK** to restore the instrument to its factory default settings.
3. Configure DG5000 Pro:
  - a. Set the output impedance of CH1 to 50  $\Omega$  (in CH1 setup interface, click or tap the **Channel** tab and select "Load" in the drop-down menu of **Imped**).
  - b. Set CH1 to output a Sine wave with 1 kHz frequency and 0 dBm amplitude.
  - c. Press the front-panel CH1 key to enable the output of CH1. You can also click or tap the channel identifier of the Channel Setup Interface to enable the output.

4. Select the AC voltage measurement function for the multimeter and enable the dBm operation. Set the reference resistance to  $50\ \Omega$  and read the measured value as the low-frequency reference power value ( $P_{ref1}$ ).



#### TIP

In this step, if the dBm operation is not enabled, you can also use the measured value ( $V_{Reading}$ ) on the multimeter and the formula " $dBm = 10 \times \lg[(V_{Reading}^2/R_{ref})/1\text{ mW}]$ " to calculate the reference power value; wherein,  $R_{ref}$  is the load impedance.

5. Keep other settings unchanged for DG5000 Pro and adjust the output frequency to 100 kHz. Record the measured value of the multimeter and verify that the "Measured Value- $P_{ref1}$ " is between -0.1 dB and +0.1 dB.
6. Calibrate the power meter:
  - a. Press the front-panel  key of the power sensor to restore the power sensor to its factory defaults.
  - b. Connect the power sensor to the input terminal and the **[POWER REF]** terminal of the power meter respectively.
  - c. Press the  key to open the Zero/Cal menu. Click or tap **Zero+Cal** to perform the calibration. After the calibration is complete, observe whether the measured value of the power meter is 0 dBm, 50 MHz.
7. Disconnect DG5000 Pro and the multimeter. Use the N-BNC adaptor to connect the power sensor to the output terminal of DG5000 Pro. This case takes CH1 as an example. The test method also applies to other channels. Use the power meter cable to connect the power sensor output terminal to the power meter input terminal, as shown in the figure below.

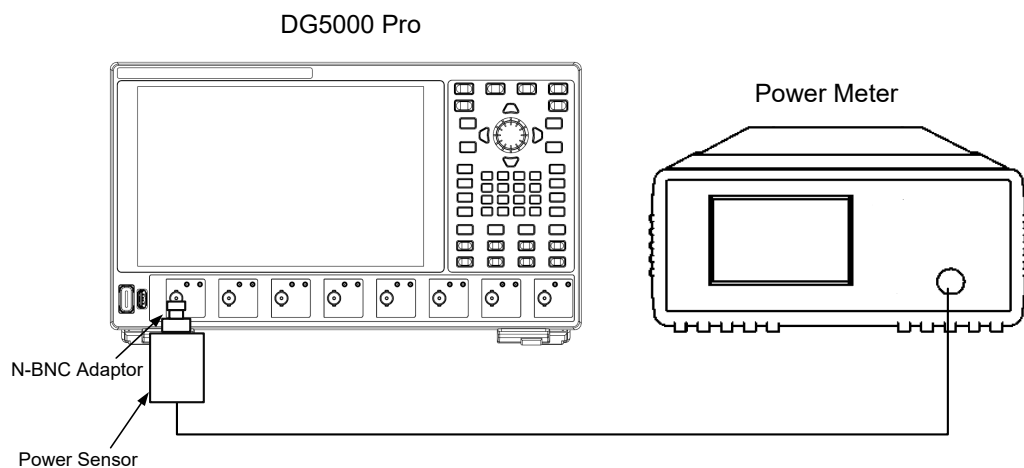

8. Keep other settings unchanged for DG5000 Pro and adjust the output frequency to 1 MHz. Set the center frequency of the power meter to 1 MHz. Record the measured value of the power meter as the high-frequency reference power value ( $P_{ref2}$ ).

9. Keep other settings unchanged for DG5000 Pro and adjust the output frequency to 2 MHz. Set the center frequency to 2 MHz for the power meter. Record the measured value and verify that the "Measured Value- $P_{ref2}$ " is between -0.1 dB and +0.1 dB.
10. Keep other settings unchanged for DG5000 Pro and adjust the output frequency to 5 MHz. Set the center frequency to 5 MHz for the power meter. Record the measured value and verify that the "Measured Value- $P_{ref2}$ " is between -0.2 dB and +0.2 dB.
11. Keep other settings unchanged for DG5000 Pro and adjust the output frequency to 50 MHz. Set the center frequency to 50 MHz for the power meter. Record the measured value and verify that the "Measured Value- $P_{ref2}$ " is between -0.5 dB and +0.5 dB.
12. Keep other settings unchanged for DG5000 Pro and adjust the output frequency to 100 MHz. Set the center frequency to 100 MHz for the power meter. Record the measured value and verify that the "Measured Value- $P_{ref2}$ " is between -1.0 dB and +1.0 dB.
13. Keep other settings unchanged for DG5000 Pro and adjust the output frequency to 200 MHz. Set the center frequency to 200 MHz for the power meter. Record the measured value and verify that the "Measured Value- $P_{ref2}$ " is between -2.0 dB and +2.0 dB.
14. Keep other settings unchanged for DG5000 Pro and adjust the output frequency to 500 MHz (DG5508 Pro/DG5504 Pro/DG5502 Pro only). Set the center frequency to 500 MHz for the power meter. Record the measured value and verify that the "Measured Value- $P_{ref2}$ " is between -2.0 dB and +2.0 dB.
15. Repeat the steps above to verify the AC flatness for other channels and record the test result.

### 4.4.3 Test Record Form

Output Channel: CH1

$P_{ref1}$  = \_\_\_\_\_  $P_{ref2}$  = \_\_\_\_\_

Frequency Setting	Setting	Measured Value	Calculation Result <sup>[1]</sup>	Limit	Pass/Fail
100 kHz	Amplitude: 0 dBm			±0.1 dB	
2 MHz				±0.1 dB	
5 MHz	Impedance: 50 Ω			±0.2 dB	
50 MHz				±0.5 dB	

Frequency Setting	Setting	Measured Value	Calculation Result <sup>[1]</sup>	Limit	Pass/Fail
100 MHz				±1 dB	
200 MHz				±2 dB	
500 MHz <sup>[2]</sup>				±2 dB	

**Channel: CH2**

$P_{ref1} = \underline{\hspace{2cm}}$   $P_{ref2} = \underline{\hspace{2cm}}$

Frequency Setting	Setting	Measured Value	Calculation Result <sup>[1]</sup>	Limit	Pass/Fail
100 kHz	Amplitude: 0 dBm Impedance: 50 Ω			±0.1 dB	
2 MHz				±0.1 dB	
5 MHz				±0.2 dB	
50 MHz				±0.5 dB	
100 MHz				±1 dB	
200 MHz				±2 dB	
500 MHz <sup>[2]</sup>				±2 dB	

**Output Channel: CH3**

$P_{ref1} = \underline{\hspace{2cm}}$   $P_{ref2} = \underline{\hspace{2cm}}$

Frequency Setting	Setting	Measured Value	Calculation Result <sup>[1]</sup>	Limit	Pass/Fail
100 kHz	Amplitude: 0 dBm Impedance: 50 Ω			±0.1 dB	
2 MHz				±0.1 dB	
5 MHz				±0.2 dB	
50 MHz				±0.5 dB	
100 MHz				±1 dB	
200 MHz				±2 dB	
500 MHz <sup>[2]</sup>				±2 dB	

**Output Channel: CH4**

$P_{ref1} = \underline{\hspace{2cm}}$   $P_{ref2} = \underline{\hspace{2cm}}$

Frequency Setting	Setting	Measured Value	Calculation Result <sup>[1]</sup>	Limit	Pass/Fail
100 kHz	Amplitude: 0 dBm Impedance: 50 Ω			±0.1 dB	
2 MHz				±0.1 dB	
5 MHz				±0.2 dB	
50 MHz				±0.5 dB	
100 MHz				±1 dB	
200 MHz				±2 dB	
500 MHz <sup>[2]</sup>				±2 dB	

**Output Channel: CH5**

$P_{ref1} = \underline{\hspace{2cm}}$   $P_{ref2} = \underline{\hspace{2cm}}$

Frequency Setting	Setting	Measured Value	Calculation Result <sup>[1]</sup>	Limit	Pass/Fail
100 kHz	Amplitude: 0 dBm Impedance: 50 Ω			±0.1 dB	
2 MHz				±0.1 dB	
5 MHz				±0.2 dB	
50 MHz				±0.5 dB	
100 MHz				±1 dB	
200 MHz				±2 dB	
500 MHz <sup>[2]</sup>				±2 dB	

**Output Channel: CH6**

$P_{ref1} = \underline{\hspace{2cm}}$   $P_{ref2} = \underline{\hspace{2cm}}$

Frequency Setting	Setting	Measured Value	Calculation Result <sup>[1]</sup>	Limit	Pass/Fail
100 kHz	Amplitude: 0 dBm			±0.1 dB	
2 MHz				±0.1 dB	

Frequency Setting	Setting	Measured Value	Calculation Result <sup>[1]</sup>	Limit	Pass/Fail
5 MHz	Impedance: 50 $\Omega$			$\pm 0.2$ dB	
50 MHz				$\pm 0.5$ dB	
100 MHz				$\pm 1$ dB	
200 MHz				$\pm 2$ dB	
500 MHz <sup>[2]</sup>				$\pm 2$ dB	

**Output Channel: CH7**

$P_{ref1} = \underline{\hspace{2cm}}$   $P_{ref2} = \underline{\hspace{2cm}}$

Frequency Setting	Setting	Measured Value	Calculation Result <sup>[1]</sup>	Limit	Pass/Fail
100 kHz	Amplitude: 0 dBm Impedance: 50 $\Omega$			$\pm 0.1$ dB	
2 MHz				$\pm 0.1$ dB	
5 MHz				$\pm 0.2$ dB	
50 MHz				$\pm 0.5$ dB	
100 MHz				$\pm 1$ dB	
200 MHz				$\pm 2$ dB	
500 MHz <sup>[2]</sup>				$\pm 2$ dB	

**Output Channel: CH8**

$P_{ref1} = \underline{\hspace{2cm}}$   $P_{ref2} = \underline{\hspace{2cm}}$

Frequency Setting	Setting	Measured Value	Calculation Result <sup>[1]</sup>	Limit	Pass/Fail
100 kHz	Amplitude: 0 dBm Impedance: 50 $\Omega$			$\pm 0.1$ dB	
2 MHz				$\pm 0.1$ dB	
5 MHz				$\pm 0.2$ dB	
50 MHz				$\pm 0.5$ dB	
100 MHz				$\pm 1$ dB	
200 MHz				$\pm 2$ dB	

Frequency Setting	Setting	Measured Value	Calculation Result <sup>[1]</sup>	Limit	Pass/Fail
500 MHz <sup>[2]</sup>				±2 dB	

Note<sup>[1]</sup>: For 100 kHz frequency, Calculation Result = Amplitude Measured Value -  $P_{ref1}$ ; for other frequencies, Calculation Result = Amplitude Measured Value -  $P_{ref2}$ .

Note<sup>[2]</sup>: for DG5508 Pro/DG5504 Pro/DG5502 Pro.

## 4.5 Harmonic Distortion Test

### 4.5.1 Specification

Sine Wave Spectral Purity	
Harmonic Distortion	Typical (0 dBm) 10 Hz to <10 MHz: <-60 dBc ≥10 MHz to <50 MHz: <-50 dBc ≥50 MHz to <200 MHz: <-45 dBc ≥200 MHz: <-35 dBc

### 4.5.2 Test Procedures

- As shown in the figure below, use the dual BNC cable and the BNC-BNC adaptor to connect the output terminal of DG5000 Pro to the RF input terminal of the spectrum analyzer. This case takes CH1 as an example. The test method also applies to other channels.

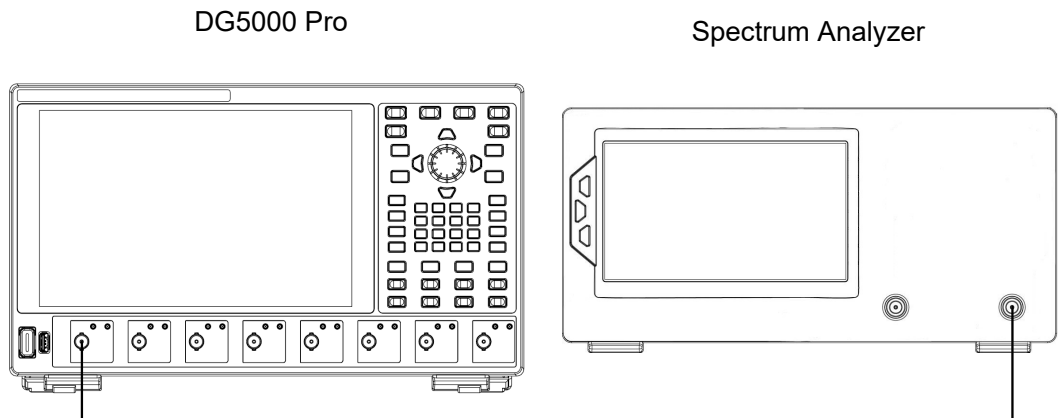

- Press the front-panel **Default** key of DG5000 Pro and a prompt message is displayed. Click or tap **OK** to restore the instrument to its factory default settings.
- Configure DG5000 Pro:

- a. Set the output impedance of CH1 to 50  $\Omega$  (in CH1 setup interface, click or tap the **Channel** tab and select "Load" in the drop-down menu of **Imped**).
  - b. Set CH1 to output a Sine wave with 1 MHz frequency, 0 dBm amplitude, and 0 Vdc offset.
  - c. Press the front-panel CH1 key to enable the output of CH1. You can also click or tap the channel identifier of the Channel Setup Interface to enable the output.
4. Set up the spectrum analyzer:
    - a. Set the input attenuation to 20 dB and the reference level to 10 dBm.
    - b. Set the start frequency to 0 Hz and the stop frequency to 5 MHz.
    - c. Set the resolution bandwidth to 1 kHz.
  5. Enable the peak table function of the spectrum analyzer and record the measured values of the fundamental wave and the second harmonic. Verify that the harmonic distortion is less than -60 dBc through calculation<sup>[1]</sup>.
  6. Keep other settings unchanged for DG5000 Pro and adjust the output frequency to 10 MHz.
  7. Set up the spectrum analyzer:
    - a. Set the input attenuation to 20 dB and the reference level to 10 dBm.
    - b. Set the start frequency to 5 MHz and the stop frequency to 30 MHz.
    - c. Set the resolution bandwidth to 1 kHz.
  8. Record the measured values of the fundamental wave and the second harmonic. Verify that the harmonic distortion is less than -50 dBc through calculation<sup>[1]</sup>.
  9. Keep other settings unchanged for DG5000 Pro and adjust the output frequency to 50 MHz.
  10. Set up the spectrum analyzer:
    - a. Set the input attenuation to 20 dB and the reference level to 10 dBm.
    - b. Set the start frequency to 40 MHz and the stop frequency to 120 MHz.
    - c. Set the resolution bandwidth to 3 kHz.
  11. Record the measured values of the fundamental wave and the second harmonic in the peak table. Verify that the harmonic distortion is less than -45 dBm through calculation<sup>[1]</sup>.
  12. Keep other settings unchanged for DG5000 Pro and adjust the output frequency to 200 MHz.

13. Set up the spectrum analyzer:
  - a. Set the input attenuation to 20 dB and the reference level to 10 dBm.
  - b. Set the start frequency to 150 MHz and the stop frequency to 500 MHz.
  - c. Set the resolution bandwidth to 3 kHz.
14. Record the measured values of the fundamental wave and the second harmonic in the peak table. Verify that the harmonic distortion is less than -35 dBc through calculation<sup>[1]</sup>.
15. Keep other settings unchanged for DG5000 Pro and adjust the output frequency to 400 MHz.
16. Set up the spectrum analyzer:
  - a. Set the input attenuation to 20 dB and the reference level to 10 dBm.
  - b. Set the start frequency to 350 MHz and the stop frequency to 1 GHz.
  - c. Set the resolution bandwidth to 3 kHz.
17. Record the measured values of the fundamental wave and the second harmonic in the peak table. Verify that the harmonic distortion is less than -35 dBc through calculation<sup>[1]</sup>.
18. Repeat the steps above to test the harmonic distortion for other channels and record the test result.

**NOTE**

[1]: The Second Harmonic Distortion = Measured Value of the Second Harmonic - Measured Value of the Fundamental Wave; For example, if the measured value of the fundamental wave is -10 dBm and the measured value of the second harmonic is -72 dBm, the second harmonic distortion = (-72) - (-10) = -62 dBc.

### 4.5.3 Test Record Form

Channel: CH1

Frequency Setting	Setting	Measured Value	Calculation Result <sup>[1]</sup>	Limit	Pass/Fail <sup>[2]</sup>	
1 MHz	Waveform: Sine	1 (Fundamental Wave):		-60 dBc		
	Amplitude: 0 dBm	2:				
	Offset: 0 Vdc					

Frequency Setting	Setting	Measured Value	Calculation Result <sup>[1]</sup>	Limit	Pass/Fail <sup>[2]</sup>
10 MHz		1 (Fundamental Wave):		-50 dBc	
		2:			
50 MHz		1 (Fundamental Wave):		-45 dBc	
		2:			
200 MHz		1 (Fundamental Wave):		-35 dBc	
		2:			
400 MHz <sup>[3]</sup>		1 (Fundamental Wave):		-35 dBc	
		2:			

**Channel: CH2**

Frequency Setting	Setting	Measured Value	Calculation Result <sup>[1]</sup>	Limit	Pass/Fail <sup>[2]</sup>
1 MHz	Waveform: Sine Amplitude: 0 dBm Offset: 0 Vdc	1 (Fundamental Wave):		<-60 dBc	
		2:			
10 MHz		1 (Fundamental Wave):		<-50 dBc	
		2:			
50 MHz		1 (Fundamental Wave):		<-45 dBc	
		2:			

Frequency Setting	Setting	Measured Value	Calculation Result <sup>[1]</sup>	Limit	Pass/Fail <sup>[2]</sup>
200 MHz		1 (Fundamental Wave):		<-35 dBc	
		2:			
400 MHz <sup>[3]</sup>		1 (Fundamental Wave):		<-35 dBc	
		2:			

**Channel: CH3**

Frequency Setting	Setting	Measured Value	Calculation Result <sup>[1]</sup>	Limit	Pass/Fail <sup>[2]</sup>
1 MHz	Waveform: Sine Amplitude: 0 dBm Offset: 0 Vdc	1 (Fundamental Wave):		-60 dBc	
		2:			
10 MHz		1 (Fundamental Wave):		-50 dBc	
		2:			
50 MHz		1 (Fundamental Wave):		-45 dBc	
		2:			
200 MHz	1 (Fundamental Wave):		-35 dBc		
	2:				
400 MHz <sup>[3]</sup>	1 (Fundamental Wave):		-35 dBc		
	2:				

## Channel: CH4

Frequency Setting	Setting	Measured Value	Calculation Result <sup>[1]</sup>	Limit	Pass/Fail <sup>[2]</sup>
1 MHz	Waveform: Sine Amplitude: 0 dBm Offset: 0 Vdc	1 (Fundamental Wave):		-60 dBc	
		2:			
10 MHz		1 (Fundamental Wave):		-50 dBc	
		2:			
50 MHz		1 (Fundamental Wave):		-45 dBc	
		2:			
200 MHz	1 (Fundamental Wave):		-35 dBc		
	2:				
400 MHz <sup>[3]</sup>	1 (Fundamental Wave):		-35 dBc		
	2:				

## Channel: CH5

Frequency Setting	Setting	Measured Value	Calculation Result <sup>[1]</sup>	Limit	Pass/Fail <sup>[2]</sup>
1 MHz	Waveform: Sine Amplitude: 0 dBm	1 (Fundamental Wave):		-60 dBc	
		2:			
10 MHz	Offset: 0 Vdc	1 (Fundamental Wave):		-50 dBc	

Frequency Setting	Setting	Measured Value	Calculation Result <sup>[1]</sup>	Limit	Pass/Fail <sup>[2]</sup>
50 MHz		2:			
		1 (Fundamental Wave):		-45 dBc	
		2:			
200 MHz		1 (Fundamental Wave):		-35 dBc	
		2:			
400 MHz <sup>[3]</sup>		1 (Fundamental Wave):		-35 dBc	
	2:				

**Channel: CH6**

Frequency Setting	Setting	Measured Value	Calculation Result <sup>[1]</sup>	Limit	Pass/Fail <sup>[2]</sup>
1 MHz	Waveform: Sine Amplitude: 0 dBm Offset: 0 Vdc	1 (Fundamental Wave):		-60 dBc	
		2:			
10 MHz		1 (Fundamental Wave):		-50 dBc	
		2:			
50 MHz		1 (Fundamental Wave):		-45 dBc	
		2:			
200 MHz	1 (Fundamental Wave):		-35 dBc		

Frequency Setting	Setting	Measured Value	Calculation Result <sup>[1]</sup>	Limit	Pass/Fail <sup>[2]</sup>
400 MHz <sup>[3]</sup>		2:		-35 dBc	
		1 (Fundamental Wave):			
		2:			

## Channel: CH7

Frequency Setting	Setting	Measured Value	Calculation Result <sup>[1]</sup>	Limit	Pass/Fail <sup>[2]</sup>
1 MHz	Waveform: Sine Amplitude: 0 dBm Offset: 0 Vdc	1 (Fundamental Wave):		-60 dBc	
		2:			
10 MHz		1 (Fundamental Wave):		-50 dBc	
		2:			
50 MHz		1 (Fundamental Wave):		-45 dBc	
		2:			
200 MHz	1 (Fundamental Wave):		-35 dBc		
	2:				
400 MHz <sup>[3]</sup>	1 (Fundamental Wave):		-35 dBc		
	2:				

## Channel: CH8

Frequency Setting	Setting	Measured Value	Calculation Result <sup>[1]</sup>	Limit	Pass/Fail <sup>[2]</sup>
1 MHz	Waveform: Sine Amplitude: 0 dBm Offset: 0 Vdc	1 (Fundamental Wave):		-60 dBc	
		2:			
10 MHz		1 (Fundamental Wave):		-50 dBc	
		2:			
50 MHz		1 (Fundamental Wave):		-45 dBc	
		2:			
200 MHz	1 (Fundamental Wave):		-35 dBc		
	2:				
400 MHz <sup>[3]</sup>	1 (Fundamental Wave):		-35 dBc		
	2:				

Note<sup>[1]</sup>: Calculation Result = Measured Value for the n<sup>th</sup> Harmonic – Measured Value for the Fundamental Wave

Note<sup>[2]</sup>: If the calculation result is greater than the limit, the test fails.

Note<sup>[3]</sup>: for DG5508 Pro/DG5504 Pro/DG5502 Pro.

## 4.6 Spurious Signal Test

### 4.6.1 Specification

**Sine Wave Spurious Signal (nonharmonic)**

Specification	<p>Typical (0 dBm)</p> <p>10 Hz to &lt;10 MHz: &lt;-60 dBc</p> <p>≥10 MHz to &lt;50 MHz: &lt;-55 dBc</p> <p>≥50 MHz: &lt;-45 dBc + 6 dBc/octave<sup>[1]</sup></p>
---------------	---

Note<sup>[1]</sup>: 6 dBc/octave means that for every doubling of the frequency, the specification increases by 6 dBc. For example, when DG5000 Pro outputs 50 MHz, the specification limit is -45 dBc; when it outputs 100 MHz, the limit is -45 dBc + 6 dBc.

## 4.6.2 Test Procedures

### Test Procedures

1. As shown in the figure below, use the dual BNC cable and the BNC-BNC adaptor to connect the output terminal of DG5000 Pro to the RF input terminal of the spectrum analyzer. This case takes CH1 as an example. The test method also applies to other channels.

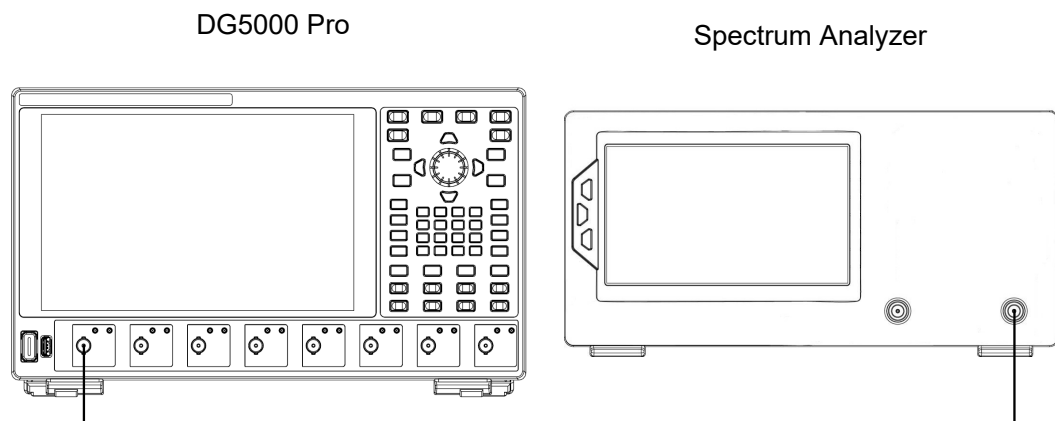

2. Press the front-panel **Default** key of DG5000 Pro and a prompt message is displayed. Click or tap **OK** to restore the instrument to its factory default settings.
3. Configure DG5000 Pro:
  - a. Set the output impedance of CH1 to 50 Ω (in CH1 setup interface, click or tap the **Channel** tab and select "Load" in the drop-down menu of **Imped**).
  - b. Set CH1 to output a Sine wave with 1 MHz frequency, 0 dBm amplitude, and 0 Vdc offset.
  - c. Press the front-panel CH1 key to enable the output of CH1. You can also click or tap the channel identifier of the Channel Setup Interface to enable the output.
4. Set up the spectrum analyzer:
  - a. Set the reference level to 10 dBm and the input attenuation to 20 dB.

- b. Set the start frequency to 0 Hz and the stop frequency to 10 MHz.
  - c. Set the resolution bandwidth to 1 kHz.
  - d. Set the peak shift to 3 dB.
  - e. Set the sweep mode to Single.
  - f. Press the front panel **Peak** key to find the maximum peak.
5. Measure the maximum spurious signal (except the harmonics) using the cursor measurement and record the test result A. Calculate the nonharmonic spurious signal (A - 0 dBm) and compare it with the specification.
  6. Keep the other settings unchanged and change the output frequency of DG5000 Pro and the stop frequency of the spectrum analyzer according to the table below. Record the max. spurious signal for each output frequency and calculate the measurement result. Compare the result with the specification.

DG5000 Pro Output Frequency	Spectrum Analyzer Stop Frequency
10 MHz	100 MHz
50 MHz	150 MHz
200 MHz	500 MHz
400 MHz	1 GHz

7. Repeat the steps above to test the spurious signal for other channels and record the test result.

### 4.6.3 Test Record Form

Channel: CH1

Output Frequency	Start Frequency	Stop Frequency	A	A - 0 dBm	Limit	Pass/Fail <sup>[1]</sup>
1 MHz	0 Hz	10 MHz			-60 dBc	
10 MHz	0 Hz	100 MHz			-55 dBc	
50 MHz	0 Hz	150 MHz			-45 dBc	
200 MHz	0 Hz	500 MHz			-27 dBc	
400 MHz	0 Hz	1 GHz			-3 dBc	

**Channel: CH2**

Output Frequency	Start Frequency	Stop Frequency	A	A - 0 dBm	Limit	Pass/ Fail <sup>[1]</sup>
1 MHz	0 Hz	10 MHz			-60 dBc	
10 MHz	0 Hz	100 MHz			-55 dBc	
50 MHz	0 Hz	150 MHz			-45 dBc	
200 MHz	0 Hz	500 MHz			-27 dBc	
400 MHz	0 Hz	1 GHz			-3 dBc	

**Channel: CH3**

Output Frequency	Start Frequency	Stop Frequency	A	A - 0 dBm	Limit	Pass/ Fail <sup>[1]</sup>
1 MHz	0 Hz	10 MHz			-60 dBc	
10 MHz	0 Hz	100 MHz			-55 dBc	
50 MHz	0 Hz	150 MHz			-45 dBc	
200 MHz	0 Hz	500 MHz			-27 dBc	
400 MHz	0 Hz	1 GHz			-3 dBc	

**Channel: CH4**

Output Frequency	Start Frequency	Stop Frequency	A	A - 0 dBm	Limit	Pass/ Fail <sup>[1]</sup>
1 MHz	0 Hz	10 MHz			-60 dBc	
10 MHz	0 Hz	100 MHz			-55 dBc	
50 MHz	0 Hz	150 MHz			-45 dBc	
200 MHz	0 Hz	500 MHz			-27 dBc	
400 MHz	0 Hz	1 GHz			-3 dBc	

**Channel: CH5**

Output Frequency	Start Frequency	Stop Frequency	A	A - 0 dBm	Limit	Pass/ Fail <sup>[1]</sup>
1 MHz	0 Hz	10 MHz			-60 dBc	

Output Frequency	Start Frequency	Stop Frequency	A	A - 0 dBm	Limit	Pass/Fail <sup>[1]</sup>
10 MHz	0 Hz	100 MHz			-55 dBc	
50 MHz	0 Hz	150 MHz			-45 dBc	
200 MHz	0 Hz	500 MHz			-27 dBc	
400 MHz	0 Hz	1 GHz			-3 dBc	

**Channel: CH6**

Output Frequency	Start Frequency	Stop Frequency	A	A - 0 dBm	Limit	Pass/Fail <sup>[1]</sup>
1 MHz	0 Hz	10 MHz			-60 dBc	
10 MHz	0 Hz	100 MHz			-55 dBc	
50 MHz	0 Hz	150 MHz			-45 dBc	
200 MHz	0 Hz	500 MHz			-27 dBc	
400 MHz	0 Hz	1 GHz			-3 dBc	

**Channel: CH7**

Output Frequency	Start Frequency	Stop Frequency	A	A - 0 dBm	Limit	Pass/Fail <sup>[1]</sup>
1 MHz	0 Hz	10 MHz			-60 dBc	
10 MHz	0 Hz	100 MHz			-55 dBc	
50 MHz	0 Hz	150 MHz			-45 dBc	
200 MHz	0 Hz	500 MHz			-27 dBc	
400 MHz	0 Hz	1 GHz			-3 dBc	

**Channel: CH8**

Output Frequency	Start Frequency	Stop Frequency	A	A - 0 dBm	Limit	Pass/Fail <sup>[1]</sup>
1 MHz	0 Hz	10 MHz			-60 dBc	
10 MHz	0 Hz	100 MHz			-55 dBc	
50 MHz	0 Hz	150 MHz			-45 dBc	

Output Frequency	Start Frequency	Stop Frequency	A	A - 0 dBm	Limit	Pass/Fail <sup>[1]</sup>
200 MHz	0 Hz	500 MHz			-27 dBc	
400 MHz	0 Hz	1 GHz			-3 dBc	

Note<sup>[1]</sup>: If the calculation result is greater than the limit, the test fails.

## 4.7 Overshoot Test

### 4.7.1 Specification

Square Overshoot	
Specification	Typical (fast transition disabled, 0 dBm amplitude, > 1 kHz frequency), < 5%

### 4.7.2 Test Procedures

- As shown in the figure below, use the dual BNC cable to connect the output terminal of DG5000 Pro to the signal input terminal of the oscilloscope. This case takes CH1 as an example. The test method also applies to other channels.

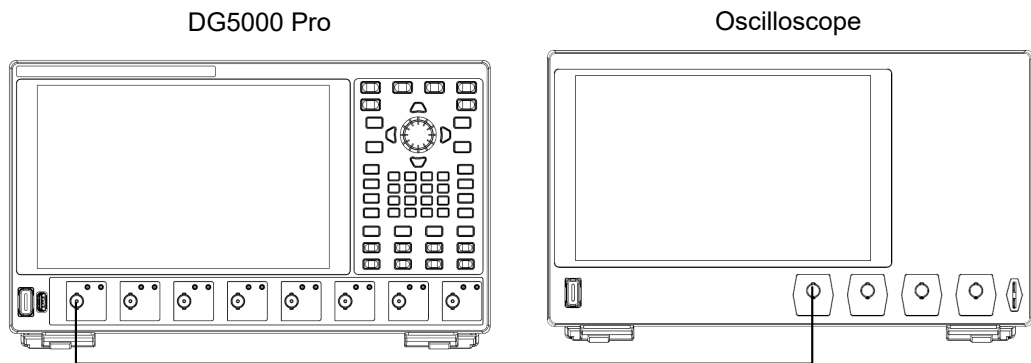

- Press the front-panel **Default** key of DG5000 Pro and a prompt message is displayed. Click or tap **OK** to restore the instrument to its factory default settings.
- Configure DG5000 Pro:
  - Set the output impedance of CH1 to 50  $\Omega$  (in CH1 setup interface, click or tap the **Channel** tab and select "Load" in the drop-down menu of **Imped**).
  - Set the CH1 to output a Square wave with 1 MHz frequency, 0 dBm amplitude, and 0 Vdc offset.
  - Press the front-panel CH1 key to enable the output of CH1. You can also click or tap the channel identifier of the Channel Setup Interface to enable the output.

4. Set up the oscilloscope:
  - a. Set the vertical scale to 200 mV/div.
  - b. Set the horizontal timebase to 100 ns.
  - c. Adjust the trigger level.
  - d. Set the input impedance to 50  $\Omega$ .
  - e. Enable the overshoot measurement function.
5. Record the measured value of the oscilloscope and verify that the value is within the specified range.
6. Repeat the steps above to test the overshoot for other channels and record the test result.

### 4.7.3 Test Record Form

#### Channel: CH1

Setting	Measured Value	Limit	Pass/Fail
Waveform: Square Frequency: 1 MHz Amplitude: 0 dBm Offset: 0 Vdc		<5%	

#### Channel: CH2

Setting	Measured Value	Limit	Pass/Fail
Waveform: Square Frequency: 1 MHz Amplitude: 0 dBm Offset: 0 Vdc		<5%	

#### Channel: CH3

Setting	Measured Value	Limit	Pass/Fail
Waveform: Square Frequency: 1 MHz Amplitude: 0 dBm Offset: 0 Vdc		<5%	

**Channel: CH4**

Setting	Measured Value	Limit	Pass/Fail
Waveform: Square Frequency: 1 MHz Amplitude: 0 dBm Offset: 0 Vdc		<5%	

**Channel: CH5**

Setting	Measured Value	Limit	Pass/Fail
Waveform: Square Frequency: 1 MHz Amplitude: 0 dBm Offset: 0 Vdc		<5%	

**Channel: CH6**

Setting	Measured Value	Limit	Pass/Fail
Waveform: Square Frequency: 1 MHz Amplitude: 0 dBm Offset: 0 Vdc		<5%	

**Channel: CH7**

Setting	Measured Value	Limit	Pass/Fail
Waveform: Square Frequency: 1 MHz Amplitude: 0 dBm Offset: 0 Vdc		<5%	

**Channel: CH8**

Setting	Measured Value	Limit	Pass/Fail
Waveform: Square Frequency: 1 MHz Amplitude: 0 dBm Offset: 0 Vdc		<5%	

## 5 Appendix: Test Record Form

### RIGOL DG5000 Pro Series Function/Arbitrary Waveform Generator Performance Verification Test Record Form

Model: \_\_\_\_\_ Tested by: \_\_\_\_\_ Test Date: \_\_\_\_\_

#### Frequency Accuracy Test

Channel: CH1

Waveform	Setting	Measured Value	Limit <sup>[1]</sup>	Pass/Fail
Sine	Frequency: 1 MHz Amplitude: 1 Vpp		0.999999 MHz to 1.000001 MHz	
Square			0.999999 MHz to 1.000001 MHz	
Ramp			0.999999 MHz to 1.000001 MHz	
Pulse			0.999999 MHz to 1.000001 MHz	
Harmonic			0.999999 MHz to 1.000001 MHz	

Channel: CH2

Waveform	Setting	Measured Value	Limit <sup>[1]</sup>	Pass/Fail
Sine	Frequency: 1 MHz Amplitude: 1 Vpp		0.999999 MHz to 1.000001 MHz	
Square			0.999999 MHz to 1.000001 MHz	
Ramp			0.999999 MHz to 1.000001 MHz	
Pulse			0.999999 MHz to 1.000001 MHz	
Harmonic			0.999999 MHz to 1.000001 MHz	

Channel: CH3

Waveform	Setting	Measured Value	Limit <sup>[1]</sup>	Pass/Fail
Sine	Frequency: 1 MHz Amplitude: 1 Vpp		0.999999 MHz to 1.000001 MHz	
Square			0.999999 MHz to 1.000001 MHz	
Ramp			0.999999 MHz to 1.000001 MHz	

Waveform	Setting	Measured Value	Limit <sup>[1]</sup>	Pass/Fail
Pulse			0.999999 MHz to 1.000001 MHz	
Harmonic			0.999999 MHz to 1.000001 MHz	

Channel: CH4

Waveform	Setting	Measured Value	Limit <sup>[1]</sup>	Pass/Fail
Sine	Frequency: 1 MHz Amplitude: 1 Vpp		0.999999 MHz to 1.000001 MHz	
Square			0.999999 MHz to 1.000001 MHz	
Ramp			0.999999 MHz to 1.000001 MHz	
Pulse			0.999999 MHz to 1.000001 MHz	
Harmonic			0.999999 MHz to 1.000001 MHz	

Channel: CH5

Waveform	Setting	Measured Value	Limit <sup>[1]</sup>	Pass/Fail
Sine	Frequency: 1 MHz Amplitude: 1 Vpp		0.999999 MHz to 1.000001 MHz	
Square			0.999999 MHz to 1.000001 MHz	
Ramp			0.999999 MHz to 1.000001 MHz	
Pulse			0.999999 MHz to 1.000001 MHz	
Harmonic			0.999999 MHz to 1.000001 MHz	

Channel: CH6

Waveform	Setting	Measured Value	Limit <sup>[1]</sup>	Pass/Fail
Sine	Frequency: 1 MHz Amplitude: : 1 Vpp		0.999999 MHz to 1.000001 MHz	
Square			0.999999 MHz to 1.000001 MHz	
Ramp			0.999999 MHz to 1.000001 MHz	
Pulse			0.999999 MHz to 1.000001 MHz	
Harmonic			0.999999 MHz to 1.000001 MHz	

Channel: CH7

Waveform	Setting	Measured Value	Limit <sup>[1]</sup>	Pass/Fail
Sine	Frequency: 1 MHz Amplitude: 1 Vpp		0.999999 MHz to 1.000001 MHz	
Square			0.999999 MHz to 1.000001 MHz	
Ramp			0.999999 MHz to 1.000001 MHz	
Pulse			0.999999 MHz to 1.000001 MHz	
Harmonic			0.999999 MHz to 1.000001 MHz	

Channel: CH8

Waveform	Setting	Measured Value	Limit <sup>[1]</sup>	Pass/Fail
Sine	Frequency: 1 MHz Amplitude: 1 Vpp		0.999999 MHz to 1.000001 MHz	
Square			0.999999 MHz to 1.000001 MHz	
Ramp			0.999999 MHz to 1.000001 MHz	
Pulse			0.999999 MHz to 1.000001 MHz	
Harmonic			0.999999 MHz to 1.000001 MHz	

Note<sup>[1]</sup>: The limit is calculated from the frequency setting value (1 MHz)  $\pm$  permissible error. The permissible error is the setting value of  $\pm 10^{-6}$  (except Arb), 0°C to 50°C.

### AC Amplitude Accuracy Test

Channel: CH1

Amplitude Setting	Setting	Measured Value	Limit <sup>[1]</sup>	Pass/Fail
20 mVpp	Frequency: 1 kHz Offset: 0 Vdc Impedance: 50 $\Omega$		6.6 mVrms to 7.5 mVrms	
100 mVpp			34.6 mVrms to 36.1 mVrms	
500 mVpp			174.7 mVrms to 178.9 mVrms	
1 Vpp			349.7 mVrms to 357.4 mVrms	
5 Vpp			1.7497Vrms to 1.7857 Vrms	

Amplitude Setting	Setting	Measured Value	Limit <sup>[1]</sup>	Pass/Fail
10 Vpp			3.4998 mVrms to 3.5712 mVrms	

Channel: CH2

Amplitude Setting	Setting	Measured Value	Limit <sup>[1]</sup>	Pass/Fail
20 mVpp	Frequency: 1 kHz Offset: 0 Vdc Impedance: 50 Ω		6.6 mVrms to 7.5 mVrms	
100 mVpp			34.6 mVrms to 36.1 mVrms	
500 mVpp			174.7 mVrms to 178.9 mVrms	
1 Vpp			349.7 mVrms to 357.4 mVrms	
5 Vpp			1.7497Vrms to 1.7857 Vrms	
10 Vpp			3.4998 mVrms to 3.5712 mVrms	

Channel: CH3

Amplitude Setting	Setting	Measured Value	Limit <sup>[1]</sup>	Pass/Fail
20 mVpp	Frequency: 1 kHz Offset: 0 Vdc Impedance: 50 Ω		6.6 mVrms to 7.5 mVrms	
100 mVpp			34.6 mVrms to 36.1 mVrms	
500 mVpp			174.7 mVrms to 178.9 mVrms	
1 Vpp			349.7 mVrms to 357.4 mVrms	
5 Vpp			1.7497Vrms to 1.7857 Vrms	
10 Vpp			3.4998 mVrms to 3.5712 mVrms	

Channel: CH4

Amplitude Setting	Setting	Measured Value	Limit <sup>[1]</sup>	Pass/Fail
20 mVpp	Frequency: 1 kHz Offset: 0 Vdc Impedance: 50 Ω		6.6 mVrms to 7.5 mVrms	
100 mVpp			34.6 mVrms to 36.1 mVrms	
500 mVpp			174.7 mVrms to 178.9 mVrms	
1 Vpp			349.7 mVrms to 357.4 mVrms	
5 Vpp			1.7497Vrms to 1.7857 Vrms	
10 Vpp			3.4998 mVrms to 3.5712 mVrms	

Channel: CH5

Amplitude Setting	Setting	Measured Value	Limit <sup>[1]</sup>	Pass/Fail
20 mVpp	Frequency: 1 kHz Offset: 0 Vdc Impedance: 50 Ω		6.6 mVrms to 7.5 mVrms	
100 mVpp			34.6 mVrms to 36.1 mVrms	
500 mVpp			174.7 mVrms to 178.9 mVrms	
1 Vpp			349.7 mVrms to 357.4 mVrms	
5 Vpp			1.7497Vrms to 1.7857 Vrms	
10 Vpp			3.4998 mVrms to 3.5712 mVrms	

Channel: CH6

Amplitude Setting	Setting	Measured Value	Limit <sup>[1]</sup>	Pass/Fail
20 mVpp	Frequency: 1 kHz		6.6 mVrms to 7.5 mVrms	
100 mVpp	Offset: 0 Vdc		34.6 mVrms to 36.1 mVrms	
500 mVpp	Impedance: 50 Ω		174.7 mVrms to 178.9 mVrms	

Amplitude Setting	Setting	Measured Value	Limit <sup>[1]</sup>	Pass/Fail
1 Vpp			349.7 mVrms to 357.4 mVrms	
5 Vpp			1.7497Vrms to 1.7857 Vrms	
10 Vpp			3.4998 mVrms to 3.5712 mVrms	

Channel: CH7

Amplitude Setting	Setting	Measured Value	Limit <sup>[1]</sup>	Pass/Fail
20 mVpp	Frequency: 1 kHz Offset: 0 Vdc Impedance: 50 Ω		6.6 mVrms to 7.5 mVrms	
100 mVpp			34.6 mVrms to 36.1 mVrms	
500 mVpp			174.7 mVrms to 178.9 mVrms	
1 Vpp			349.7 mVrms to 357.4 mVrms	
5 Vpp			1.7497Vrms to 1.7857 Vrms	
10 Vpp			3.4998 mVrms to 3.5712 mVrms	

Channel: CH8

Amplitude Setting	Setting	Measured Value	Limit <sup>[1]</sup>	Pass/Fail
20 mVpp	Frequency: 1 kHz Offset: 0 Vdc Impedance: 50 Ω		6.6 mVrms to 7.5 mVrms	
100 mVpp			34.6 mVrms to 36.1 mVrms	
500 mVpp			174.7 mVrms to 178.9 mVrms	
1 Vpp			349.7 mVrms to 357.4 mVrms	
5 Vpp			1.7497Vrms to 1.7857 Vrms	
10 Vpp			3.4998 mVrms to 3.5712 mVrms	

Note<sup>[1]</sup>: 1 kHz Sine, amplitude > 1 mVpp, 0 Vdc offset, unit: Vpp.  $\pm(1\%$  of the setting value + 1 mVpp).

### DC Offset Accuracy Test

Channel: CH1

Offset Setting	Setting	Measured Value	Limit <sup>[1]</sup>	Pass/Fail
-2.5 Vdc	Frequency: 1 kHz Amplitude: 5 Vpp Impedance: 50 $\Omega$		-2.551 Vdc to -2.449 Vdc	
-1 Vdc			-1.036 Vdc to -0.964 Vdc	
-500 mVdc			-0.531 Vdc to -0.469 Vdc	
0 Vdc			-0.026 Vdc to +0.026 Vdc	
+500 mVdc			0.469 Vdc to 0.531 Vdc	
+1 Vdc			0.964 Vdc to 1.036 Vdc	
+2.5 Vdc			2.449 Vdc to 2.551 Vdc	

Channel: CH2

Offset Setting	Setting	Measured Value	Limit <sup>[1]</sup>	Pass/Fail
-2.5 Vdc	Frequency: 1 kHz Amplitude: 5 Vpp Impedance: 50 $\Omega$		-2.551 Vdc to -2.449 Vdc	
-1 Vdc			-1.036 Vdc to -0.964 Vdc	
-500 mVdc			-0.531 Vdc to -0.469 Vdc	
0 Vdc			-0.026 Vdc to +0.026 Vdc	
+500 mVdc			0.469 Vdc to 0.531 Vdc	
+1 Vdc			0.964 Vdc to 1.036 Vdc	
+2.5 Vdc			2.449 Vdc to 2.551 Vdc	

Channel: CH3

Offset Setting	Setting	Measured Value	Limit <sup>[1]</sup>	Pass/Fail
-2.5 Vdc	Frequency: 1 kHz		-2.551 Vdc to -2.449 Vdc	
-1 Vdc	Amplitude: 5 Vpp		-1.036 Vdc to -0.964 Vdc	

Offset Setting	Setting	Measured Value	Limit <sup>[1]</sup>	Pass/Fail
-500 mVdc	Impedance: 50 $\Omega$		-0.531 Vdc to -0.469 Vdc	
0 Vdc			-0.026 Vdc to +0.026 Vdc	
+500 mVdc			0.469 Vdc to 0.531 Vdc	
+1 Vdc			0.964 Vdc to 1.036 Vdc	
+2.5 Vdc			2.449 Vdc to 2.551 Vdc	

Channel: CH4

Offset Setting	Setting	Measured Value	Limit <sup>[1]</sup>	Pass/Fail
-2.5 Vdc	Frequency: 1 kHz Amplitude: 5 Vpp Impedance: 50 $\Omega$		-2.551 Vdc to -2.449 Vdc	
-1 Vdc			-1.036 Vdc to -0.964 Vdc	
-500 mVdc			-0.531 Vdc to -0.469 Vdc	
0 Vdc			-0.026 Vdc to +0.026 Vdc	
+500 mVdc			0.469 Vdc to 0.531 Vdc	
+1 Vdc			0.964 Vdc to 1.036 Vdc	
+2.5 Vdc			2.449 Vdc to 2.551 Vdc	

Channel: CH5

Offset Setting	Setting	Measured Value	Limit <sup>[1]</sup>	Pass/Fail
-2.5 Vdc	Frequency: 1 kHz Amplitude: 5 Vpp Impedance: 50 $\Omega$		-2.551 Vdc to -2.449 Vdc	
-1 Vdc			-1.036 Vdc to -0.964 Vdc	
-500 mVdc			-0.531 Vdc to -0.469 Vdc	
0 Vdc			-0.026 Vdc to +0.026 Vdc	
+500 mVdc			0.469 Vdc to 0.531 Vdc	
+1 Vdc			0.964 Vdc to 1.036 Vdc	
+2.5 Vdc			2.449 Vdc to 2.551 Vdc	

Channel: CH6

Offset Setting	Setting	Measured Value	Limit <sup>[1]</sup>	Pass/Fail
-2.5 Vdc	Frequency: 1 kHz Amplitude: 5 Vpp Impedance: 50 Ω		-2.551 Vdc to -2.449 Vdc	
-1 Vdc			-1.036 Vdc to -0.964 Vdc	
-500 mVdc			-0.531 Vdc to -0.469 Vdc	
0 Vdc			-0.026 Vdc to +0.026 Vdc	
+500 mVdc			0.469 Vdc to 0.531 Vdc	
+1 Vdc			0.964 Vdc to 1.036 Vdc	
+2.5 Vdc			2.449 Vdc to 2.551 Vdc	

Channel: CH7

Offset Setting	Setting	Measured Value	Limit <sup>[1]</sup>	Pass/Fail
-2.5 Vdc	Frequency: 1 kHz Amplitude: 5 Vpp Impedance: 50 Ω		-2.551 Vdc to -2.449 Vdc	
-1 Vdc			-1.036 Vdc to -0.964 Vdc	
-500 mVdc			-0.531 Vdc to -0.469 Vdc	
0 Vdc			-0.026 Vdc to +0.026 Vdc	
+500 mVdc			0.469 Vdc to 0.531 Vdc	
+1 Vdc			0.964 Vdc to 1.036 Vdc	
+2.5 Vdc			2.449 Vdc to 2.551 Vdc	

Channel: CH8

Offset Setting	Setting	Measured Value	Limit <sup>[1]</sup>	Pass/Fail
-2.5 Vdc	Frequency: 1 kHz Amplitude: 5 Vpp Impedance: 50 Ω		-2.551 Vdc to -2.449 Vdc	
-1 Vdc			-1.036 Vdc to -0.964 Vdc	
-500 mVdc			-0.531 Vdc to -0.469 Vdc	
0 Vdc			-0.026 Vdc to +0.026 Vdc	
+500 mVdc			0.469 Vdc to 0.531 Vdc	

Offset Setting	Setting	Measured Value	Limit <sup>[1]</sup>	Pass/Fail
+1 Vdc			0.964 Vdc to 1.036 Vdc	
+2.5 Vdc			2.449 Vdc to 2.551 Vdc	

Note<sup>[1]</sup>: The offset limit value is calculated from the offset setting value  $\pm$  permissible error. The permissible error is calculated from the specification " $\pm(1\%$  of |the setting value| + 1 mVdc + 0.5% of the amplitude (Vpp))".

### AC Flatness Test

Channel: CH1

P<sub>ref1</sub> = \_\_\_\_\_ P<sub>ref2</sub> = \_\_\_\_\_

Frequency Setting	Setting	Measured Value	Calculation Result <sup>[1]</sup>	Limit	Pass/Fail
100 kHz	Amplitude: 0 dBm Impedance: 50 $\Omega$			$\pm 0.1$ dB	
2 MHz				$\pm 0.1$ dB	
5 MHz				$\pm 0.2$ dB	
50 MHz				$\pm 0.5$ dB	
100 MHz				$\pm 1$ dB	
200 MHz				$\pm 2$ dB	
500 MHz <sup>[2]</sup>				$\pm 2$ dB	

Channel: CH2

P<sub>ref</sub> = \_\_\_\_\_

Frequency Setting	Setting	Measured Value	Calculation Result <sup>[1]</sup>	Limit	Pass/Fail
2 MHz	Amplitude: 0 dBm Impedance: 50 $\Omega$			$\pm 0.1$ dB	
5 MHz				$\pm 0.2$ dB	
50 MHz				$\pm 0.5$ dB	
100 MHz				$\pm 1$ dB	
200 MHz				$\pm 2$ dB	
500 MHz <sup>[2]</sup>				$\pm 2$ dB	

Channel: CH3

 $P_{ref1} = \underline{\hspace{2cm}}$   $P_{ref2} = \underline{\hspace{2cm}}$ 

Frequency Setting	Setting	Measured Value	Calculation Result <sup>[1]</sup>	Limit	Pass/Fail
100 kHz	Amplitude: 0 dBm Impedance: 50 $\Omega$			$\pm 0.1$ dB	
2 MHz				$\pm 0.1$ dB	
5 MHz				$\pm 0.2$ dB	
50 MHz				$\pm 0.5$ dB	
100 MHz				$\pm 1$ dB	
200 MHz				$\pm 2$ dB	
500 MHz <sup>[2]</sup>				$\pm 2$ dB	

Channel: CH4

 $P_{ref1} = \underline{\hspace{2cm}}$   $P_{ref2} = \underline{\hspace{2cm}}$ 

Frequency Setting	Setting	Measured Value	Calculation Result <sup>[1]</sup>	Limit	Pass/Fail
100 kHz	Amplitude: 0 dBm Impedance: 50 $\Omega$			$\pm 0.1$ dB	
2 MHz				$\pm 0.1$ dB	
5 MHz				$\pm 0.2$ dB	
50 MHz				$\pm 0.5$ dB	
100 MHz				$\pm 1$ dB	
200 MHz				$\pm 2$ dB	
500 MHz <sup>[2]</sup>				$\pm 2$ dB	

Channel: CH5

 $P_{ref1} = \underline{\hspace{2cm}}$   $P_{ref2} = \underline{\hspace{2cm}}$ 

Frequency Setting	Setting	Measured Value	Calculation Result <sup>[1]</sup>	Limit	Pass/Fail
100 kHz	Amplitude: 0 dBm Impedance: 50 $\Omega$			$\pm 0.1$ dB	
2 MHz				$\pm 0.1$ dB	
5 MHz				$\pm 0.2$ dB	

Frequency Setting	Setting	Measured Value	Calculation Result <sup>[1]</sup>	Limit	Pass/Fail
50 MHz				±0.5 dB	
100 MHz				±1 dB	
200 MHz				±2 dB	
500 MHz <sup>[2]</sup>				±2 dB	

Channel: CH6

 $P_{ref1} = \underline{\hspace{2cm}}$   $P_{ref2} = \underline{\hspace{2cm}}$ 

Frequency Setting	Setting	Measured Value	Calculation Result <sup>[1]</sup>	Limit	Pass/Fail
100 kHz	Amplitude: 0 dBm Impedance: 50 Ω			±0.1 dB	
2 MHz				±0.1 dB	
5 MHz				±0.2 dB	
50 MHz				±0.5 dB	
100 MHz				±1 dB	
200 MHz				±2 dB	
500 MHz <sup>[2]</sup>				±2 dB	

Channel: CH7

 $P_{ref1} = \underline{\hspace{2cm}}$   $P_{ref2} = \underline{\hspace{2cm}}$ 

Frequency Setting	Setting	Measured Value	Calculation Result <sup>[1]</sup>	Limit	Pass/Fail
100 kHz	Amplitude: 0 dBm Impedance: 50 Ω			±0.1 dB	
2 MHz				±0.1 dB	
5 MHz				±0.2 dB	
50 MHz				±0.5 dB	
100 MHz				±1 dB	
200 MHz				±2 dB	
500 MHz <sup>[2]</sup>				±2 dB	

Channel: CH8

 $P_{ref1} = \underline{\hspace{2cm}}$   $P_{ref2} = \underline{\hspace{2cm}}$ 

Frequency Setting	Setting	Measured Value	Calculation Result <sup>[1]</sup>	Limit	Pass/Fail
100 kHz	Amplitude: 0 dBm Impedance: 50 $\Omega$			$\pm 0.1$ dB	
2 MHz				$\pm 0.1$ dB	
5 MHz				$\pm 0.2$ dB	
50 MHz				$\pm 0.5$ dB	
100 MHz				$\pm 1$ dB	
200 MHz				$\pm 2$ dB	
500 MHz <sup>[2]</sup>				$\pm 2$ dB	

Note<sup>[1]</sup>: For 100 kHz frequency, Calculation Result = Amplitude Measured Value -  $P_{ref1}$ ; for other frequencies, Calculation Result = Amplitude Measured Value -  $P_{ref2}$ .

Note<sup>[2]</sup>: for DG5508 Pro/DG5504 Pro/DG5502 Pro.

### Harmonic Distortion Test

Channel: CH1

Frequency Setting	Setting	Measured Value	Calculation Result <sup>[1]</sup>	Limit	Pass/Fail
1 MHz	Waveform: Sine Amplitude: 0 dBm Offset: 0 Vdc	1 (Fundamental Wave):		< -60 dBc	
		2:			
10 MHz		1 (Fundamental Wave):		< -50 dBc	
		2:			
50 MHz		1 (Fundamental Wave):		< -45 dBc	
		2:			

Frequency Setting	Setting	Measured Value	Calculation Result <sup>[1]</sup>	Limit	Pass/Fail
200 MHz		1 (Fundamental Wave):		<-35 dBc	
		2:			
400 MHz <sup>[2]</sup>		1 (Fundamental Wave):		<-35 dBc	
		2:			

Channel: CH2

Frequency Setting	Setting	Measured Value	Calculation Result <sup>[1]</sup>	Limit	Pass/Fail
1 MHz	Waveform: Sine Amplitude: 0 dBm Offset: 0 Vdc	1 (Fundamental Wave):		<-60 dBc	
		2:			
10 MHz		1 (Fundamental Wave):		<-50 dBc	
		2:			
50 MHz		1 (Fundamental Wave):		<-45 dBc	
		2:			
200 MHz	1 (Fundamental Wave):	<-35 dBc			
	2:				
400 MHz <sup>[2]</sup>	1 (Fundamental Wave):	<-35 dBc			
	2:				

Channel: CH3

Frequency Setting	Setting	Measured Value	Calculation Result <sup>[1]</sup>	Limit	Pass/Fail
1 MHz	Waveform: Sine Amplitude: 0 dBm Offset: 0 Vdc	1 (Fundamental Wave):		<-60 dBc	
		2:			
10 MHz		1 (Fundamental Wave):		<-50 dBc	
		2:			
50 MHz		1 (Fundamental Wave):		<-45 dBc	
		2:			
200 MHz	1 (Fundamental Wave):		<-35 dBc		
	2:				
400 MHz <sup>[2]</sup>	1 (Fundamental Wave):		<-35 dBc		
	2:				

Channel: CH4

Frequency Setting	Setting	Measured Value	Calculation Result <sup>[1]</sup>	Limit	Pass/Fail
1 MHz	Waveform: Sine Amplitude: 0 dBm Offset: 0 Vdc	1 (Fundamental Wave):		<-60 dBc	
		2:			
10 MHz		1 (Fundamental Wave):		<-50 dBc	

Frequency Setting	Setting	Measured Value	Calculation Result <sup>[1]</sup>	Limit	Pass/Fail
50 MHz		2:			
		1 (Fundamental Wave):		<-45 dBc	
2:					
200 MHz		1 (Fundamental Wave):		<-35 dBc	
		2:			
400 MHz <sup>[2]</sup>		1 (Fundamental Wave):		<-35 dBc	
	2:				

Channel: CH5

Frequency Setting	Setting	Measured Value	Calculation Result <sup>[1]</sup>	Limit	Pass/Fail
1 MHz	Waveform: Sine Amplitude: 0 dBm Offset: 0 Vdc	1 (Fundamental Wave):		<-60 dBc	
		2:			
10 MHz		1 (Fundamental Wave):		<-50 dBc	
		2:			
50 MHz		1 (Fundamental Wave):		<-45 dBc	
		2:			
200 MHz		1 (Fundamental Wave):		<-35 dBc	

Frequency Setting	Setting	Measured Value	Calculation Result <sup>[1]</sup>	Limit	Pass/Fail
		2:			
400 MHz <sup>[2]</sup>		1 (Fundamental Wave):		<-35 dBc	
		2:			

Channel: CH6

Frequency Setting	Setting	Measured Value	Calculation Result <sup>[1]</sup>	Limit	Pass/Fail
1 MHz		1 (Fundamental Wave):		<-60 dBc	
		2:			
10 MHz		1 (Fundamental Wave):		<-50 dBc	
		2:			
50 MHz	Waveform: Sine Amplitude: 0 dBm Offset: 0 Vdc	1 (Fundamental Wave):		<-45 dBc	
		2:			
200 MHz		1 (Fundamental Wave):		<-35 dBc	
		2:			
400 MHz <sup>[2]</sup>		1 (Fundamental Wave):		<-35 dBc	
		2:			

Channel: CH7

Frequency Setting	Setting	Measured Value	Calculation Result <sup>[1]</sup>	Limit	Pass/Fail						
1 MHz	Waveform: Sine Amplitude: 0 dBm Offset: 0 Vdc	1 (Fundamental Wave):		<-60 dBc							
		2:									
10 MHz		1 (Fundamental Wave):					<-50 dBc				
		2:									
50 MHz		1 (Fundamental Wave):								<-45 dBc	
		2:									
200 MHz	1 (Fundamental Wave):		<-35 dBc								
	2:										
400 MHz <sup>[2]</sup>	1 (Fundamental Wave):					<-35 dBc					
	2:										

Channel: CH8

Frequency Setting	Setting	Measured Value	Calculation Result <sup>[1]</sup>	Limit	Pass/Fail			
1 MHz	Waveform: Sine Amplitude: 0 dBm Offset: 0 Vdc	1 (Fundamental Wave):		<-60 dBc				
		2:						
10 MHz		1 (Fundamental Wave):					<-50 dBc	
		2:						

Frequency Setting	Setting	Measured Value	Calculation Result <sup>[1]</sup>	Limit	Pass/Fail
50 MHz		1 (Fundamental Wave):		<-45 dBc	
		2:			
200 MHz		1 (Fundamental Wave):		<-35 dBc	
		2:			
400 MHz <sup>[2]</sup>		1 (Fundamental Wave):		<-35 dBc	
		2:			

Note<sup>[1]</sup>: Calculation Result = Measured Value for the n<sup>th</sup> Harmonic – Measured Value for the Fundamental Wave

Note<sup>[2]</sup>: for DG5508 Pro/DG5504 Pro/DG5502 Pro.

### Spurious Signal Test

Channel: CH1

Output Frequency	Start Frequency	Stop Frequency	A	A - 0 dBm	Limit	Pass/Fail
1 MHz	0 Hz	10 MHz			<-60 dBc	
10 MHz	0 Hz	100 MHz			<-55 dBc	
50 MHz	0 Hz	150 MHz			<-45 dBc	
200 MHz	0 Hz	500 MHz			<-27 dBc	
400 MHz <sup>[1]</sup>	0 Hz	1 GHz			<-3 dBc	

Channel: CH2

Output Frequency	Start Frequency	Stop Frequency	A	A - 0 dBm	Limit	Pass/Fail
1 MHz	0 Hz	10 MHz			<-60 dBc	
10 MHz	0 Hz	100 MHz			<-55 dBc	

Output Frequency	Start Frequency	Stop Frequency	A	A - 0 dBm	Limit	Pass/Fail
50 MHz	0 Hz	150 MHz			<-45 dBc	
200 MHz	0 Hz	500 MHz			<-27 dBc	
400 MHz <sup>[1]</sup>	0 Hz	1 GHz			<-3 dBc	

Channel: CH3

Output Frequency	Start Frequency	Stop Frequency	A	A - 0 dBm	Limit	Pass/Fail
1 MHz	0 Hz	10 MHz			<-60 dBc	
10 MHz	0 Hz	100 MHz			<-55 dBc	
50 MHz	0 Hz	150 MHz			<-45 dBc	
200 MHz	0 Hz	500 MHz			<-27 dBc	
400 MHz <sup>[1]</sup>	0 Hz	1 GHz			<-3 dBc	

Channel: CH4

Output Frequency	Start Frequency	Stop Frequency	A	A - 0 dBm	Limit	Pass/Fail
1 MHz	0 Hz	10 MHz			<-60 dBc	
10 MHz	0 Hz	100 MHz			<-55 dBc	
50 MHz	0 Hz	150 MHz			<-45 dBc	
200 MHz	0 Hz	500 MHz			<-27 dBc	
400 MHz <sup>[1]</sup>	0 Hz	1 GHz			<-3 dBc	

Channel: CH5

Output Frequency	Start Frequency	Stop Frequency	A	A - 0 dBm	Limit	Pass/Fail
1 MHz	0 Hz	10 MHz			<-60 dBc	
10 MHz	0 Hz	100 MHz			<-55 dBc	
50 MHz	0 Hz	150 MHz			<-45 dBc	
200 MHz	0 Hz	500 MHz			<-27 dBc	

Output Frequency	Start Frequency	Stop Frequency	A	A - 0 dBm	Limit	Pass/Fail
400 MHz <sup>[1]</sup>	0 Hz	1 GHz			<-3 dBc	

Channel: CH6

Output Frequency	Start Frequency	Stop Frequency	A	A - 0 dBm	Limit	Pass/Fail
1 MHz	0 Hz	10 MHz			<-60 dBc	
10 MHz	0 Hz	100 MHz			<-55 dBc	
50 MHz	0 Hz	150 MHz			<-45 dBc	
200 MHz	0 Hz	500 MHz			<-27 dBc	
400 MHz <sup>[1]</sup>	0 Hz	1 GHz			<-3 dBc	

Channel: CH7

Output Frequency	Start Frequency	Stop Frequency	A	A - 0 dBm	Limit	Pass/Fail
1 MHz	0 Hz	10 MHz			<-60 dBc	
10 MHz	0 Hz	100 MHz			<-55 dBc	
50 MHz	0 Hz	150 MHz			<-45 dBc	
200 MHz	0 Hz	500 MHz			<-27 dBc	
400 MHz <sup>[1]</sup>	0 Hz	1 GHz			<-3 dBc	

Channel: CH8

Output Frequency	Start Frequency	Stop Frequency	A	A - 0 dBm	Limit	Pass/Fail
1 MHz	0 Hz	10 MHz			<-60 dBc	
10 MHz	0 Hz	100 MHz			<-55 dBc	
50 MHz	0 Hz	150 MHz			<-45 dBc	
200 MHz	0 Hz	500 MHz			<-27 dBc	
400 MHz <sup>[1]</sup>	0 Hz	1 GHz			<-3 dBc	

Note<sup>[1]</sup>: for DG5508 Pro/DG5504 Pro/DG5502 Pro.

**Overshoot Test**

Channel: CH1

Setting	Measured Value	Limit	Pass/ Fail
Waveform: Square Frequency: 1 MHz Amplitude: 0 dBm Offset: 0 Vdc		<5%	

Channel: CH2

Setting	Measured Value	Limit	Pass/ Fail
Waveform: Square Frequency: 1 MHz Amplitude: 0 dBm Offset: 0 Vdc		<5%	

Channel: CH3

Setting	Measured Value	Limit	Pass/ Fail
Waveform: Square Frequency: 1 MHz Amplitude: 0 dBm Offset: 0 Vdc		<5%	

Channel: CH4

Setting	Measured Value	Limit	Pass/ Fail
Waveform: Square Frequency: 1 MHz Amplitude: 0 dBm Offset: 0 Vdc		<5%	

Channel: CH5

Setting	Measured Value	Limit	Pass/ Fail
Waveform: Square Frequency: 1 MHz Amplitude: 0 dBm Offset: 0 Vdc		<5%	

Channel: CH6

Setting	Measured Value	Limit	Pass/ Fail
Waveform: Square Frequency: 1 MHz Amplitude: 0 dBm Offset: 0 Vdc		<5%	

Channel: CH7

Setting	Measured Value	Limit	Pass/ Fail
Waveform: Square Frequency: 1 MHz Amplitude: 0 dBm Offset: 0 Vdc		<5%	

Channel: CH8

Setting	Measured Value	Limit	Pass/ Fail
Waveform: Square Frequency: 1 MHz Amplitude: 0 dBm Offset: 0 Vdc		<5%	

# Boost Smart World and Technology Innovation

Industrial Intelligent  
Manufacturing



Semiconductors

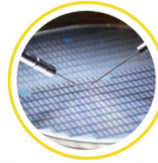

Education &  
Research

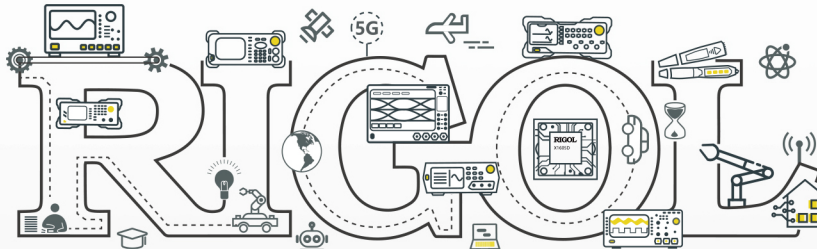

Communication

System Integration



New Energy



- 5G Cellular-5G/WIFI
- UWB/RFID/ ZIGBEE
- Digital Bus/Ethernet
- Optical Communication

- Digital/Analog/RF Chip
- Memory and MCU Chip
- Third-Generation Semiconductor
- Solar Photovoltaic Cells

- New Energy Automobile
- PV/Inverter
- Power Test
- Automotive Electronics

*Provide Testing and Measuring Products  
and Solutions for Industry Customers*

## HEADQUARTER

**RIGOL TECHNOLOGIES CO., LTD.**  
No.8 Keling Road, New District,  
Suzhou, JiangSu, P.R.China  
Tel: +86-400620002  
Email: info-cn@rigol.com

## JAPAN

**RIGOL JAPAN CO., LTD.**  
5F, 3-45-6, Minamiotsuka, Toshima-Ku,  
Tokyo, 170-0005, Japan  
Tel: +81-3-6262-8932  
Fax: +81-3-6262-8933  
Email: info.jp@rigol.com

## EUROPE

**RIGOL TECHNOLOGIES EU GmbH**  
Carl-Benz-Str.11  
82205 Gilching  
Germany  
Tel: +49(0)8105-27292-0  
Email: info-europe@rigol.com

## KOREA

**RIGOL KOREA CO., LTD.**  
5F, 222, Gonghang-daero,  
Gangseo-gu, Seoul, Republic of Korea  
Tel: +82-2-6953-4466  
Fax: +82-2-6953-4422  
Email: info.kr@rigol.com

## NORTH AMERICA

**RIGOL TECHNOLOGIES, USA INC.**  
10220 SW Nimbus Ave.  
Suite K-7  
Portland, OR 97223  
Tel: +1-877-4-RIGOL-1  
Email: sales@rigol.com

## For Assistance in Other Countries

Email: info.int@rigol.com

**RIGOL®** is the trademark of **RIGOL TECHNOLOGIES CO., LTD.** Product information in this document is subject to update without notice. For the latest information about **RIGOL's** products, applications and services, please contact local **RIGOL** channel partners or access **RIGOL** official website: [www.rigol.com](http://www.rigol.com)